

**T.C.
ISTANBUL AYDIN UNIVERSITY
INSTITUTE OF NATURAL AND APPLIED SCIENCES**



**UWB MICROSTRIP ANTENNA DESIGN FOR MICROWAVE IMAGING
SYSTEMS**

THESIS

Nasir IQBAL

**Department of Electrical and Electronics Engineering
Electrical and Electronics Engineering Program**

MAY, 2017

**T.C.
ISTANBUL AYDIN UNIVERSITY
INSTITUTE OF NATURAL AND APPLIED SCIENCES**



**UWB MICROSTRIP ANTENNA DESIGN FOR MICROWAVE IMAGING
SYSTEMS**

M.Sc. THESIS

**Nasir Iqbal
(Y1513.300004)**

**Department of Electrical and Electronics Engineering
Electrical and Electronics Engineering Program**

Thesis Advisor: Assist. Prof. Dr. Saeid KARAMZADEH

MAY, 2017





T.C.
İSTANBUL AYDIN ÜNİVERSİTESİ
FEN BİLİMLER ENSTİTÜSÜ MÜDÜRLÜĞÜ

Yüksek Lisans Tez Onay Belgesi

Enstitümüz Elektrik-Elektronik (İngilizce) Mühendisliği Ana Bilim Dalı Elektrik-Elektronik Mühendisliği (İngilizce) Tezli Yüksek Lisans Programı Y1513.300004 numaralı öğrencisi Nasır IQBAL'ın "UWB MICROSTRIP ANTENNA DESING FOR MICROWAVE IMAGING SYSTEMS" adlı tez çalışması Enstitümüz Yönetim Kurulunun 16.05.2017 tarih ve 2017/11 sayılı kararıyla oluşturulan jüri tarafından Dr. Evrim Tetik ile Tezli Yüksek Lisans tezi olarak Kabul edilmiştir.

Öğretim Üyesi Adı Soyadı

İmzası

Tez Savunma Tarihi :24/05/2017

1)Tez Danışmanı: Yrd. Doç. Dr. Saad KARAMZADEH

2) Jüri Üyesi : Yrd. Doç. Dr. Evrim TETİK

3) Jüri Üyesi : Prof. Dr. Hasan Hüseyin BALIK

.....
.....
.....

Not: Öğrencinin Tez savunmasında **Başarılı** olması halinde bu form imzalanacaktır. Aksi halde geçersizdir.





To my Parents,,



FOREWORD

I declare that this thesis entitled “UWB Microstrip Antenna Design for Microwave Imaging Systems”, submitted as requirement for the award of M.Sc. Electrical and Electronics Engineering degree, does not contain any material previously published or submitted by other person except where due reference is made in the text.

I want to thank wholeheartedly my supervisor, Assistant Professor Dr. Saeid KARAMZADEH, for this opportunity that he offered me to work and for his devotion, guidance and direction all through this thesis.

May, 2017

Nasir IQBAL

(Student)



TABLE OF CONTENT

	Page
FOREWORD	vii
TABLE OF CONTENT	ix
ABBREVIATIONS	xi
LIST OF FIGURES	xiii
ÖZET	xv
ABSTRACT	xvii
1 INTRODUCTION	1
1.1 Ultra-wide band antenna	1
1.2 Application	3
1.2.1 Microwave imaging	3
1.2.2 Mobile communication	4
1.2.3 Global Positioning Satellite (GPS) Systems	5
1.2.4 Underwater communication	5
1.3 Thesis framework	6
2 ANTENNAS	9
2.1 Antenna types	9
2.1.1 Dipole antenna	9
2.1.2 Reflector antenna	11
2.1.3 Array antenna	11
2.1.4 Aperture antenna	12
2.1.5 Lens antenna.....	13
2.1.6 Microstrip antenna	13
2.2 Parameters	14
2.2.1 Return loss.....	15
2.2.2 Voltage Standing Wave Ratio.....	15
2.2.3 Directivity D.....	16
2.2.4 Gain G.....	17
2.2.5 Radiation Pattern.....	18
2.2.6 Radiation Intensity	19
2.2.7 Bandwidth	20
2.2.8 Polarization	20
3 MICROSTRIP ANTENNA	23
3.1 Design of microstrip antenna.....	25
3.1.1 Feed technique	26
3.2 Properties.....	29
3.2.1 Dimension	31

3.2.2	Impedance Matching	31
3.3	Coplanar Waveguide (CPW)	32
4	PROPOSED WORK	35
4.1	High Frequency Structural Simulator (HFSS).....	36
4.2	Design of proposed antenna	37
4.3	Results	41
4.3.1	Return loss	41
4.3.2	Voltage Standing Wave Ratio	44
4.3.3	Gain of propose antenna.....	47
4.3.4	Radiation pattern	50
5	CONCLUSION	55
	REFERENCES	57
	RESUME	60

ABBREVIATIONS

FBW	: Fractional Bandwidth
FCC	: Federal Communication Commission
HFSS	: High Frequency Structural Simulator
UWB	: Ultra-wide Band
2D	: Two Dimensional
3D	: Three Dimensional
VSWR	: Voltage Standing Wave Ratio
CPW	: Coplanar Waveguide
MIC	: Microwave Integrated Circuit
MRI	: Magnetic resonance imaging



LIST OF FIGURES

	Page
Figure 1.1 Ultra-wide band spectrum.....	2
Figure 1.2 Normal and cancerous cells	4
Figure 1.3 Global positioning satellite	5
Figure 1.4 under water womunication	6
Figure 2.1 Dipole antenna	10
Figure 2.2 Reflector antenna	11
Figure 2.3 Array antenna.....	12
Figure 2.4 Aperture antenna.....	12
Figure 2.5 Lens antenna	13
Figure 2.6 Patch antenna	14
Figure 2.7 Return loss, S11	15
Figure 2.8 Voltage Standing Wave Ratio	16
Figure 2.9 Directivity of different antenna.....	17
Figure 2.10 Gain (dB) of Antenna	18
Figure 2.11 2D Radiation Pattern of Antenn.....	19
Figure 2.12 3D Radiation Pattern of Antenna.....	19
Figure 2.13 (a) Linear Polarization, (b) Circular Polarization, (c) Elliptical Polarization	21
Figure 3.1 Microstrip antenna	23
Figure 3.2 Different shapes of patch	25
Figure 3.3 Fringing field	26
Figure 3.4 Microstrip feed Line	27
Figure 3.5 Coaxial probe feeding technique	27
Figure 3.6 Aperture coupling feeding technique.....	28
Figure 3.7 Proximity coupling feeding technique.....	29
Figure 3.8 Dimensions of simple rectangular microstrip patch antenna.....	30
Figure 3.9 Flow of current in resonating length.....	31
Figure 3.10 V, I, Z Distribution along resonant length	32
Figure 3.11 Coplanar waveguide antenna	33
Figure 4.1 High Frequency Structural Simulator Interface.....	36
Figure 4.2 Simple design of proposed antenna	37
Figure 4.3 I Stub and Inverted L slit in ground.....	38
Figure 4.4 Inset-feed and slits in patch	39
Figure 4.5 Circular shape hole in centre of patch	39
Figure 4.6 Designing parameter of proposed antenna.....	40
Figure 4.7 Return loss (dB) of simple design of proposed antenna	42

Figure 4.8 Return loss of antenna with I stub and Inverted L slit in ground.....	42
Figure 4.9 Return loss with Inset-feed and slits in patch	43
Figure 4.10 Return loss of proposed antenna	43
Figure 4.11 Return Loss of antenna (a) Simple design of proposed antenna (b) Stub and Inverted L slit in ground (c) Inset-feed and slits in patch (d) Circular shape hole in centre of patch.....	44
Figure 4.12 VSWR of simple design of proposed antenna	45
Figure 4.13 VSWR of antenna with I stub and Inverted L slit in ground	45
Figure 4.14 VSWR with Inset-feed and slits in patch.....	46
Figure 4.15 VSWR of proposed antenna.....	46
Figure 4.16 VSWR of of antenna (a) Simple design of proposed antenna (b) Stub and Inverted L slit in ground (c) Inset-feed and Slits in patch (d) Circular shape hole in centre of patch	47
Figure 4.17 Gain of simple design of proposed antenna.....	48
Figure 4.18 Gain of antenna with I stub and Inverted L slits in ground	48
Figure 4.19 Gain with Inset-feed and slits in patch.....	49
Figure 4.20 Gain of Proposed Antenna	49
Figure 4.21 Gain of antenna (a) Simple design of proposed antenna (b) Stub and Inverted L slit in ground (c) Inset-feed and slits in patch (d) Circular shape hole in centre of patch.....	50
Figure 4.22 2D representation of radiation patterns (a) $\Phi = 0^\circ$, (b) $\Phi = 90^\circ$, (c) $\Theta = 90^\circ$	51
Figure 4.23 3D representation of radiation patterns.....	52
Figure 4.24 Current distribution in proposed antenna.....	52

MİKRODALGA GÖRÜNTÜLEME SİSTEMLERİ İÇİN UGB MİKROŞERİT ANTEN TASARIMI

ÖZET

Bu tezde, kanseri tespiti gibi mikrodalga görüntüleme uygulamaları için kullanılabilen bir UGB (Ultra geniş bant) mikro şerit anten tasarlanmıştır. Normal dokular ve kanserli dokuların elektriksel özelliklerinin farklı olmasından dolayı kanserli dokuların tespiti mümkün olabilir. Bu uygulama için yüksek kazançlı bir UGB anteni kullanılabilir. Ultra geniş bant frekans aralığını kullanan mikro şerit anten uygulaması olan mikrodalga görüntülemenin, diğerlerine kıyasla düşük maliyetli ve etkili olması, ağır makine içeren, örneğin MRI gibi çok maliyetli diğer teknikler arasında daha popüler olmasını sağlar. Mikrodalga görüntüleme etkilenen dokuların çoğunu algılayacak kadar duyarlıdır. Ultra geniş bantlı sistemler, 2002'de Amerikan Federal İletişim Komisyonu'nun (FCC) tanımına göre, en az % 25'lik kesirli bant genişliği veya 1.5 GHz veya daha fazla çalışma frekansı aralığında olan cihazlardır.

Başlangıçta, mikro şerit antenlerin temellerini ve türlerini teknik bilgi açısından ayrıntılı olarak açıkladık. Dipol, dizi ve reflektör antenleri gibi çeşitli anten türleri vardır, ancak mikro şerit yama antenleri olarak bilinen özel anten tiplerine odaklandık. Antenlerin, geri dönüş kaybı, gerilim duran dalga oranı ve kazanç gibi önemli parametreleri, antenin radyasyon özelliklerini anlamaya yardımcı olur. Dönüş kaybı, sinyaldeki güç kaybıdır, bu da iletim hattında tutarlılık eksikliği nedeniyle geri yansır. Nispeten mikro şerit antenlerin verimlilik, boyut ve maliyet bakımından diğer antenlere göre pek çok avantajı vardır. Mikroşerit besleme hattı kolay imalat nedeniyle yaygın olarak kullanılırken, empedans eşleştirmesi besleme hattı boyut ve konumuna göre geliştirilebilir.

Önerilen antende kullanılan alt tabaka 1.6mm kalınlığında, göreceli geçirgenliği 4.4 ve kayıp teğeti 0.02 olan bir FR4'tür. Frekans Aralığı, 2.01 GHz - 7.64 GHz arasındadır ve Kesirli Bant Genişliği (FBW) %116'dır. Anten, 38 mm uzunluğunda ve 40 mm genişliğinde düşük maliyetli düşük profilli alt tabaka kullanıyor. Kısacası ultra geniş bant uygulamaları için çok kompakt bir tasarım yaratılmıştır. Yayılma yaması, 23.5×12 mm² boyutlarında dikdörtgen biçimli yama içerir. Yamadaki radyasyon verimliliğini ve elektrik alan dağılımını arttırmak için bir saplama eklendi. Mikroşerit besleme hattı 50Ω empedans sağlamak için kullanıldı. Anten, mikrodalga görüntüleme amacı için oldukça iyi bir kazanç (9.40 dB) a sahiptir. Antenin yapısını tasarlamak ve analiz etmek için yüksek frekanslı yapısal simülatör (HFSS) kullanıldı.

Anahtar Kelimeler: *ultra geniş bant, mikro şerit anten, mikrodalga görüntüleme, kanseri tespiti*



UWB MICROSTRIP ANTENNA DESIGN FOR MICROWAVE IMAGING SYSTEMS

ABSTRACT

In this thesis, an UWB microstrip antenna is designed which can be used for microwave imaging applications such as breast cancer detection. Detection of cancerous tissues can be possible because of the difference between electrical properties of normal tissues and cancerous tissues. A high gain UWB antenna can be used for this application. Microwave imaging, which is the application of microstrip antenna utilizing ultra-wide band frequency range, is low cost and effective compared to others, which makes it more popular amongst other techniques that involve heavy machinery, which cost a lot, such as MRI. Microwave imaging is sensitive in detecting most of the affected tissues. Ultra-wide band devices, as explained by Federal Communication Commission (FCC) in 2002, are devices that have fractional bandwidth of at least 25% or operating frequency range of 1.5 GHz or more.

In the beginning, we described the basics of patches and their types with detail in terms of technical information. There are several types of antennas such as dipole, array, and reflector antennas, but we focused on the special type of antennas known as microstrip patch antennas. Important parameters of antennas such as return loss, voltage standing wave ratio, and gain help to understand the radiation characteristics of antenna. Return loss is the power loss in the signal, which is reflected back because of the lack of coherence in the transmission line, while voltage standing wave ratio is the coefficient of return loss. Comparatively microstrip antennas have many advantages over other antennas in terms of efficiency, size and cost. Microstrip antennas consist of a radiating patch mounted on one side of the dielectric substrate and grounded on the other side. Radiating patch is fed with different techniques such as microstrip feeding line, coaxial probe, aperture coupling and proximity coupling. These techniques are categorized either contacting or non-contacting. Microstrip feed line is commonly used because of easy fabrication while impedance matching can be improved by size and position of feed line.

Proposed antenna consists of a radiating patch on one side of substrate while ground on the other side. Substrate used in proposed antenna is FR4 with the thickness of 1.6 mm having relative permittivity, ϵ_r of 4.4 and loss tangent, δ equals to 0.02. Frequency range is in between 2.01 GHz to 7.64 GHz having a Fractional Bandwidth (FBW) of 116%. Antenna is using low cost low profile substrate with length of 38 mm and width of 40 mm. In short, a very compact design is created for ultra-wide band applications. Reducing the size of antenna affect the performance of antenna such as; varying thickness affect the bandwidth of antenna. Radiating patch consist of rectangular shape patch having length and width of $23.5 \times 12 \text{ mm}^2$. Stub is introduced to enhance the

radiation efficiency and electric field distribution in the patch. Microstrip feed line is used to provide 50Ω impedance. Antenna can provide better gain of 9.40 dB, which is considerably a good result for microwave imaging purpose. High frequency structural simulator (HFSS) is used to design and analyze the structure of antenna.

Keywords: *Ultra-wide band, microstrip antenna, microwave imaging, cancer detection*



1 INTRODUCTION

According to American Cancer Society, cancer is a disease that causes cells to follow abnormal changes and grown up unusually [1]. According to report mostly women are affected by breast cancer. Researcher used microwave signals to tackle with this issue and detect the properties of abnormal cells and tissues which is called microwave imaging. Antenna is the basic unit which is commonly used in medical purposes and communication systems. Antennas simulation and design is important to understand the communication system, as it is depending on specific frequency range and operating in a proper frequency band. Certain frequency bands, which are used in detecting diseases in human body and wireless communication i-e; Ultra-wide band (UWB), GSM bands, Universal Mobile Telecommunication Systems (UMTS) and UMTS 3G bands and Wireless Fidelity (Wi-Fi) / Wireless Local Area Networks (WLAN) bands, will be discussed in this section. Single antenna is not capable to operate these entire frequencies band. There is one way to use different antennas and cover these frequency bands but it will cost and also take a lot more space instead of we use a single antenna, which cover up all these multiple purposes. UWB antenna operates in a wideband region while multiband antenna is defined as the antenna which operates at several different frequencies. Most of the time these antenna such as; Dipole, Patch, Planner Inverted F and Slot antennas are used in which Dipole is used externally and Patch, PIFA and slot antenna are Internal are used internally. This thesis includes the detection of cancerous tissues using UWB microstrip patch antenna.

1.1 Ultra-wide band antenna

In 2002, federal communication commission (FCC) based in America, proposed the definition of ultra-wide band. According to commission, ultra-wide band devices are those having fractional bandwidth are more than 25% or operates in the frequency range of 1.5 GHz or more [2]. European Telecommunications Standards Institute (ETSI) also

defines the Ultra wide band region which is in between 3.4 GHz to 8.5 GHz [3]. Fractional bandwidth can be found out by using equation (1.1).

$$FBW = \frac{f_H - f_L}{f_H + f_L} \times 200\% \quad (1.1)$$

Operating range can be defined by using S11 parameter value which should be less than -10dB. If we draw a graph of frequency on the x-axis while return loss on the y-axis, it can be seen clearly that frequency at certain range is less than -10dB while defines the operating range. f_L is minimum frequency of the operating range where return loss is start to be less than -10dB and f_H is maximum frequency of the range where return loss ends being less than -10dB. As voltage standing wave ratio (VSWR) is depending on the return loss of antenna which is explained in chapter 2. Bandwidth can also be seen from voltage standing wave ratio which should be less than 2 during operating region. Equation 1.2 is showing relationship between return loss and voltage standing wave ratio, used for finding voltage standing wave ratio of antenna [4]. Figure 1.1, we can differentiate the distribution of frequency in terms of their bandwidth. As we can see the narrow is denoted by W_{NB} while ultra-wide band is denoted by W_{UWB} .

$$VSWR = \frac{1 + |\Gamma|}{1 - |\Gamma|} \quad (1.2)$$

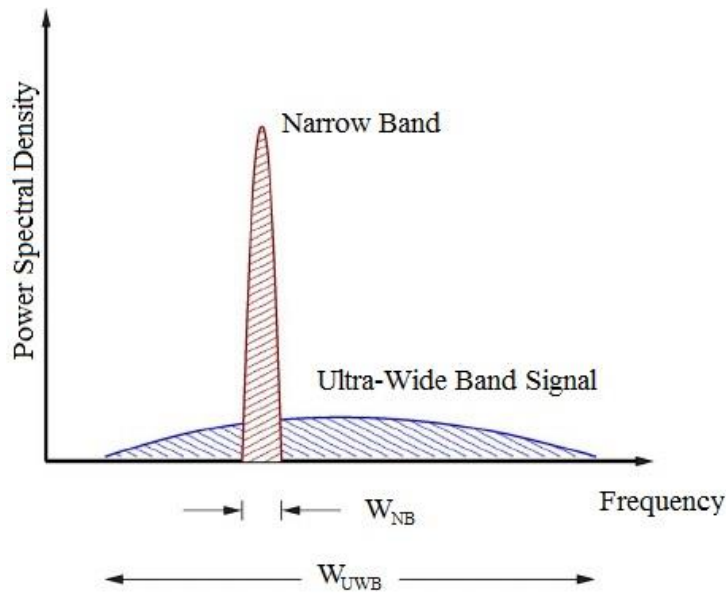

Figure 1.1 Ultra-wide band spectrum

1.2 Application

In order to go ahead, the application is important to discuss in further detail. Researchers always working on getting high resolution and data rate in low cost. Generally antenna is designed for different purposes such as; Microwave Imaging, Mobile Communication, Global Positioning satellite (GPS) Systems, Underwater Communication, Satellites Communication and Radar, Electromagnetic Testing etc. Applications of antenna based on the enhanced efficiency, gain, low cost and high transmission rate, which plays an important role in any kind of antenna's output. The better gain will lead us to the efficient communication with low loss.

1.2.1 Microwave imaging

Microwave Imaging is one of the most emerging fields in terms of research. Researchers are focusing on the usefulness of ultra-wide band region to make it applicable for medical purposes. It is useful and commonly used in cancer detection because of its simplicity and easy layout, which makes it more popular as compare to other detection techniques. Microwave Imaging uses the ultra-wide band which is applicable in medical purpose, through-wall imaging systems, communication and measurement systems, surveillance and radar communication.

Microwave imaging is basically used to find out the unusual object in a body to detect cancer. It is finding out the electrical property distribution of body in which there is a considerable difference between normal tissues and cancerous tissues leads us to find out the successful detection. The reason why we use microwave radiations for cancer detection purpose is that it is a secure process. According to patient's point of view, it does not involve any harmful and vulnerable situation during whole examination. During microwave imaging, power supplied in tissues is examined before and already used for mobile communications and heating tumorous tissues. Institute of electrical and electronics engineering (IEEE) defined the safety measures for maximum exposure of a body to microwave signals and their absorption rate. Equation 1.3 shows us the mathematical representation of absorption rate dependency on energy and volume of tissues [5].

$$SAR = \frac{dW}{\rho dV} \quad (1.3)$$

Where dW the energy of signal is, dV is the volume of the tissues and ρ is the density of the absorbing body. Specific absorption rate (SAR) unit is W/kg. Thus, we can clearly see that it keeps required energy level while using in detection of cancerous tissues [6].

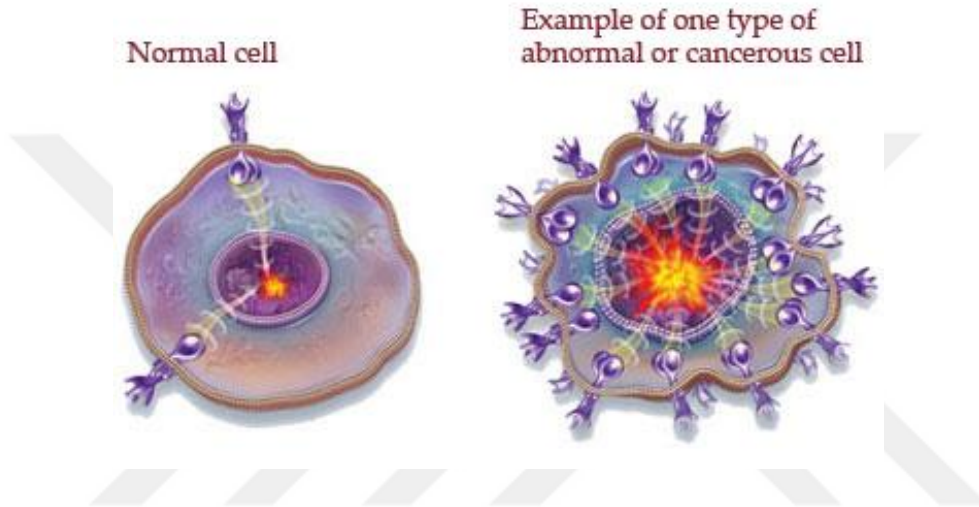

Figure 1.2 Normal and cancerous cells

In figure 1.2, it can be seen that cancerous cell has many complexities as compared to normal cell. Because of these complexities the property of cell has considerable differences which lead us to find out the affected part. On the other hand, it is low cost and effective as compared other techniques such as MRI involve heavy machinery which cost a lot. Microwave imaging is sensitive in detecting most of the affected tissues. Electrical parameter difference is important to be noticed during this process as there is considerable difference in conductivity and dielectric permittivity [7] [8].

1.2.2 Mobile communication

Antenna used for mobile communication is low cost and low profile antenna having small size. Most of the time, antennas are Omni-directional, which is receiving and transmitting in all direction. There can be several type of antenna for example planar inverted-F antenna, folded inverted conformal antenna and mono pole. Mobile communication is a great milestone in field of communication. Innovation has been made every single day which help to increase the efficiency and usefulness of antenna.

Efficiency in term of size, cost, fabrication and design, because of its importance in every system to make it compact, but still we have some tradeoff in certain locus [9].

1.2.3 Global Positioning Satellite (GPS) Systems

GPS is used to locate an object by using satellite navigation. Satellite sends unique orbital signals to receiver antenna which is used to find out the exact position; speed and time of an object. There are up to 24 satellites working in space for navigation purpose. Satellite was used by US military for the first time for defense purpose. In figure 1.3, we can see how different satellite is sending and receiving the signals and finding out the location. Later on many advantages have been taken from this satellite [10].

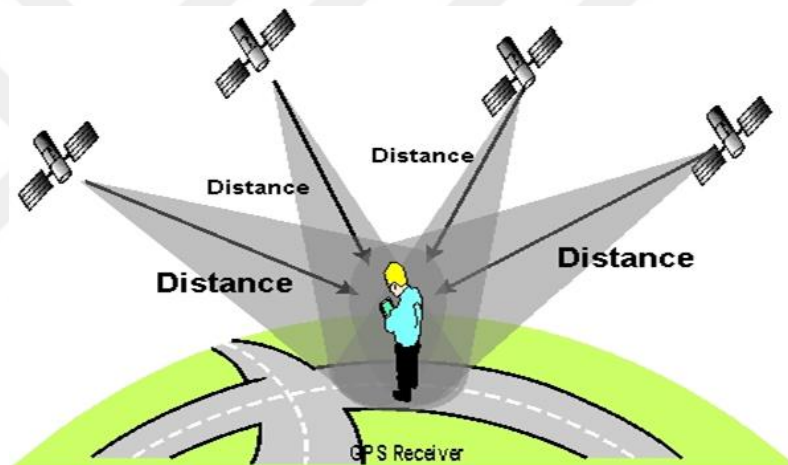

Figure 1.3 Global positioning satellite

1.2.4 Underwater communication

Underwater communication is also an application of antenna, transmitting and receiving useful signals under water. It is mostly used in between submarines under the sea, as submarine is at high risk when it is above water level. Underwater communication makes it very easy for submarines and divers to communicate even in water during several situations. In the same way we can also consider satellite communication, which make is world as global village. It becomes easier to communicate even thousands of miles [11].

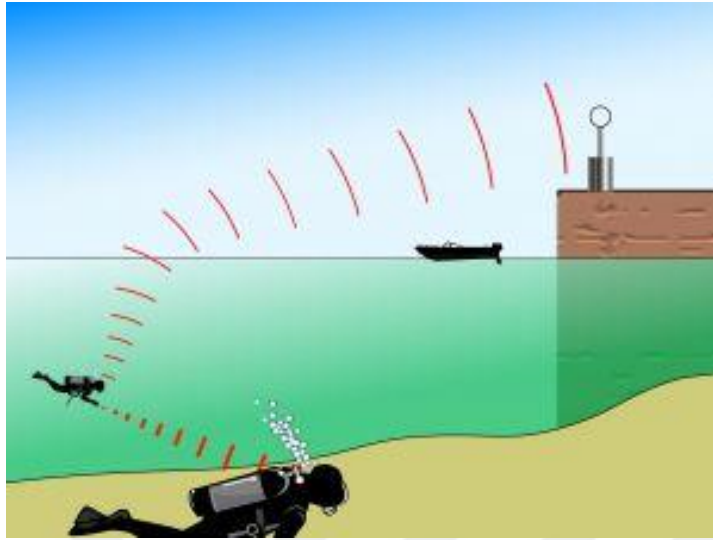

Figure 1.4 under water communication

We cannot deny the practical application of antennas and its outcomes with the current era, as every single day comes with the new ideas. Antenna is considered as one of the rich field in terms of research and innovation. Figure 1.4 is showing the underwater communication happening between divers.

1.3 Thesis framework

In this thesis framework, all the chapter and overview has been discussed. Systematic documentation of every research work is important for better understanding therefore we categorically describe this thesis in many chapters. This thesis is consisting of five chapters, which includes the definitions, properties, designing particularly proposed antenna, figurative results and their application for practical use. Chapter 2, named as Antennas, is the detailed introduction of antenna and their parameters. Antenna types are also discussed which gives a brief idea about few types of antenna. Advantages of microstrip antenna are also discussed, which will lead us to the next chapter.

Chapter 3 is particularly defining the whole concept of microstrip antenna. This chapter includes designing, feeding techniques, properties, advantages and disadvantages. Chapter 4, named as Proposed Work, is going to be the complete description of concept and design of UWB microstrip antenna which can be used in microwave imaging systems. In this chapter we explained the steps of how we proceed towards the final

design. It also includes the output results of designed antenna such as return loss, voltage standing wave ratio (VSWR), gain and radiation pattern. Chapter 5 is conclusion, which is concluding the thesis and proposes future scope for researcher.





2 ANTENNAS

Antenna is basically a type of conductor which is designed in a special structure to receive and transmit electromagnetic wave in air.

Antenna can also be defined as “the device which is used to convert the electrical power to electromagnetic waves and vice versa”.

2.1 Antenna types

As we know, some antennas are working in a specific direction while some of them are working in all direction. Antennas can be classified in many ways, we will see in this section that some of them is having large size and working in a long distances. There is also a type of antenna which is low cost, low profile and having better gain and efficiency. Antenna is a broad topic and it has many types which are discussed in detail in this section.

2.1.1 Dipole antenna

They are actually wire antenna, which is the simplest and very commonly used type of antenna. It is cheap, versatile and almost used everywhere. Dipole antenna, half wavelength dipole, folded dipole and loop antenna is included in this category. The radiation pattern of dipole antenna is almost same in all direction. The gain and radiation characteristics of the antenna are depending on the electrical length which directly influenced the frequency of operation. Suppose the power is distributed in all direction equally and power transmitted is denoted by P_t then the power density will be given by following equation (2.1)

$$W_o = e_t \frac{P_t}{4\pi R^2} \quad (2.1)$$

For understanding the general form of transmission equation can be mentioned in following equation (2.2)

$$\frac{P_r}{P_t} = e_r e_t \frac{\lambda^2 D_t(\theta_t, \phi_t) D_r(\theta_r, \phi_r)}{(4\pi R)^2} \quad (2.2)$$

Where P_r is power received and P_t power transmitted by an antenna while e_r and e_t is the efficiency of antenna and D_t and D_r is the directivity in a given direction. Maximum effective area of dipole and folded dipole is different which affect the gain of antenna while we also know that gain is directly related to directivity which can be seen in equation (2.3).

$$G = eD(\theta, \phi) \quad (2.3)$$

Since the effective area A_r of the receiving antenna is related to its efficiency e_r and directivity D_r by following equation (2.4) [12]. Figure 2.1 shows the dipole antenna.

$$A_r = e_r D_r(\theta_r, \phi_r) \left(\frac{\lambda^2}{4\pi} \right) \quad (2.4)$$

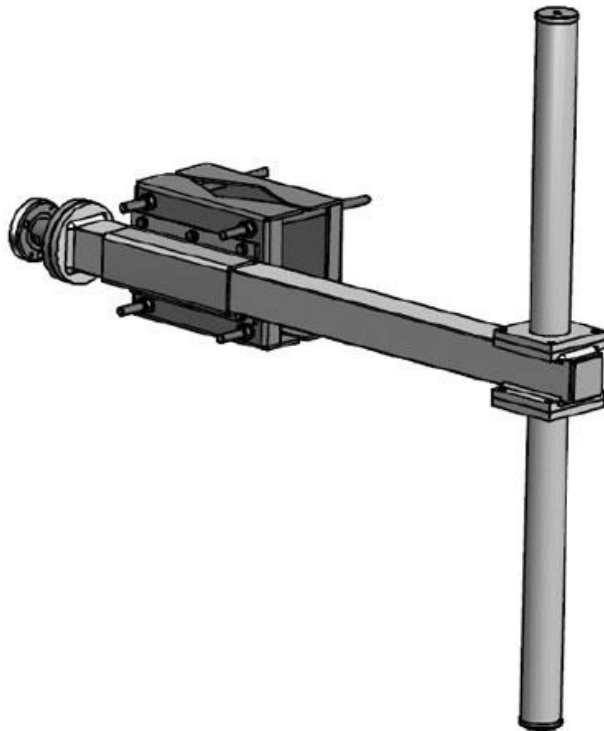

Figure 2.1 Dipole antenna

2.1.2 Reflector antenna

This antenna is used to reflect or collect the signals at concentrated point. For large distances communication it is important to built antenna with a huge distance covering. Reflector antenna is having high gain such as 30 to 40 dB; narrow beam width because of extra-ordinary large size up to 305 meters. It can cover up to thousands of miles in satellite communication. Smaller size dish antenna can be somewhere in between 2 GHz to 28 GHz while large sized dish antenna can be operating in between 30 MHz to 300 MHz [13]. Reflector antenna is shown in figure 2.2.



Figure 2.2 Reflector antenna

2.1.3 Array antenna

A set of two or more antenna combine to form a single antenna for enhanced gain and reduction of interference with a better directivity. There is also disadvantage such as increase in cost, complexity and size of antenna. Arrays help to improve the throughput and multi information system [14]. In figure 2.3, Yagi-Uda can be considered as the example of array antenna with the gain greater than 10 dB most of the time. It can typically operate in the range of 3 MHz to 3 GHz [15].

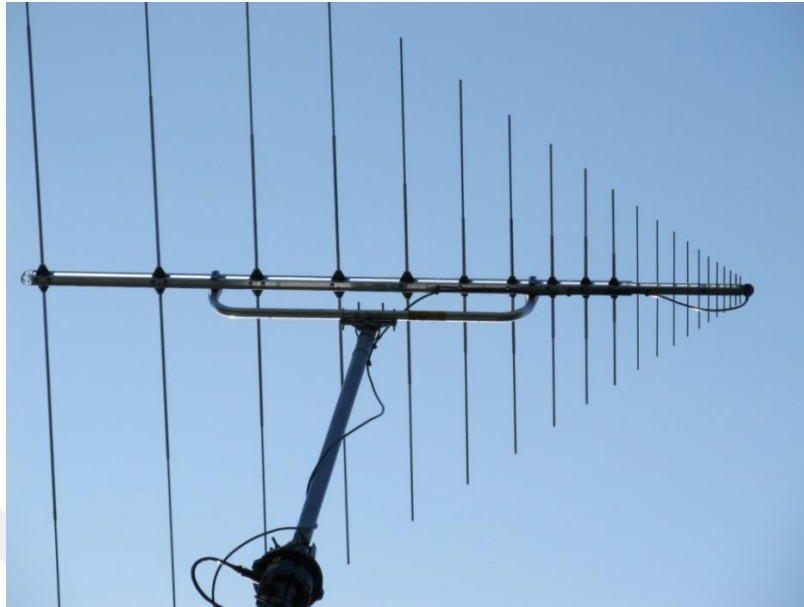

Figure 2.3 Array antenna

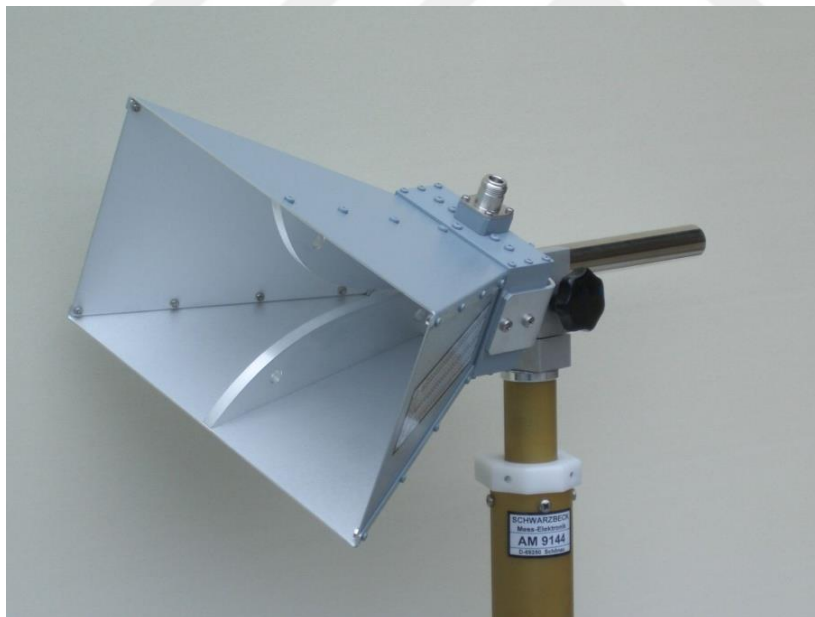

Figure 2.4 Aperture antenna

2.1.4 Aperture antenna

Aperture antenna is hollow from inside and having higher directivity and gain with the wide impedance bandwidth. It has a very low loss and simple to manufacture, as it can be seen in figure 2.4. Gain is commonly in the range of 10 dB to 20 dB but in some occasion it can reach up to 25 dB which is comparatively very high gain and can be

utilize for many purposes such as radio astronomy, satellite communications, in communication dishes as feeders, in measurements, etc [16].

2.1.5 Lens antenna

Antenna in which lens is introduced in front of aperture or dipole antenna to concentrate the signals in desired position. Lens antenna is having enhanced directivity and can be used for high transmission rate. Operating frequency is usually more than 3 GHz. The lens antenna is not so better as compared to other antennas in terms of cost, size and shape there it can be use for specific purpose only and not so common [17]. Lens can be concave or convex depending upon the usage and our requirements. Convex lens is used to converge the signal to concentrated position while concave lens is used to diverge the signal. The directivity can be improved using lens. Figure 2.5, lens in introduced in front of aperture antenna to get required application from antenna.



Figure 2.5 Lens antenna

2.1.6 Microstrip antenna

Patch antenna is use almost everywhere because of its better efficiency and low profile structure. Radiating patch is printed on the upper side of substrate while ground is on the lower side. Patch and ground is made up of high conducting material. Thickness of substrate is small but should not lesser than $1/40$ times wavelength to not affect the gain negatively. It can be fabricated in a very low cost on printed circuit board and thus it has

a very wide range of applications such as mobile communication, GPS, satellite communication, military purpose [18] [19].

Patch antenna has many advantages over other antennas such it has easy configuration as compare to other. Because of small size it is very low cost and can be used in sleek objects. Mechanically robust and having both linear and circular polarization. Also it has capability of multiband frequency operation which is useful in using single antenna for multi tasking [20]. Figure 2.6 shows us the simple patch antenna which has a coaxial probe in the bottom. Radiating patch is on the top side of substrate. Patch antenna is discussed briefly in terms of properties, design and fabrication in chapter 3.

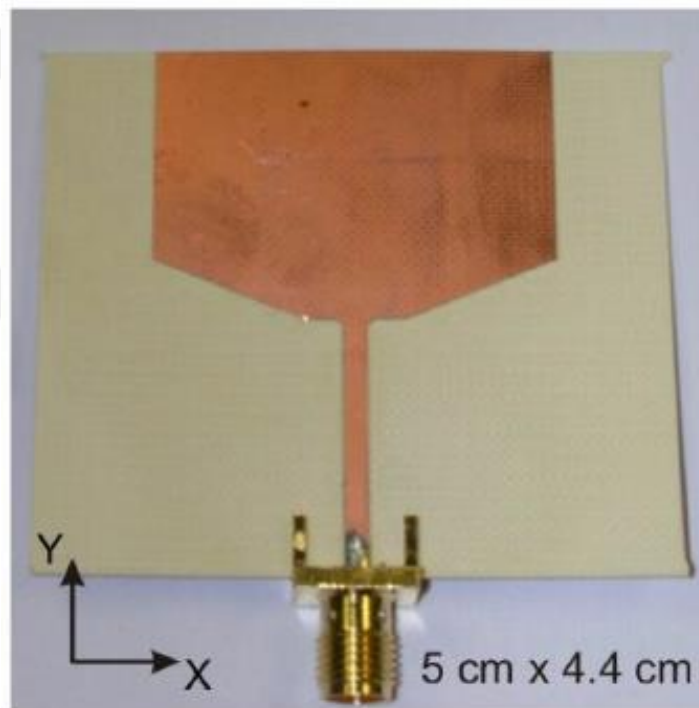

Figure 2.6 Patch antenna

2.2 Parameters

To understand the complete mechanism of antenna we must have to study the parameters, which is discussing. These parameters include return loss, VSWR, radiation pattern and gain etc. The reason behind discussing these parameters is to understand the radiation characteristics and capability of antenna.

2.2.1 Return loss

The power loss in the signal, which is reflected back because of lack of coherence in the transmission line, is known as return loss. This lack of coherence occurs by the mismatching of transmission line and antenna. It can also be known as S11, and the curve which shows S11 parameter is known as return loss curve. Return loss should be less than -10 dB on the point of interest, which is actually a particular frequency as it has its own importance in designing an antenna [21] [22]. Figure 2.7 is showing a clear example of return loss on 10 GHz.



Figure 2.7 Return loss, S11

2.2.2 Voltage Standing Wave Ratio

Voltage standing wave ratio (VSWR) is the function of reflection coefficient of antenna which tells us the power reflected back from antenna because of mismatch between antenna and transmission line [21] [22]. VSWR can be represented as follow in equation (2.5).

$$VSWR = \frac{1 + |\Gamma|}{1 - |\Gamma|} \quad (2.5)$$

The least value of VSWR is 1 and it can be up to ∞ such as $1 < VSWR < \infty$; at the VSWR of antenna less than 2 will have better power transmission as it can be seen in figure 2.8.

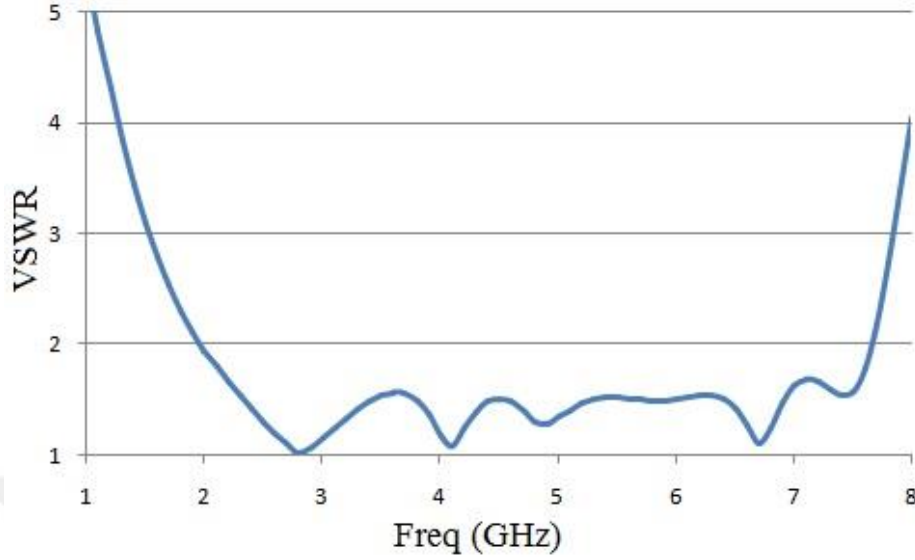

Figure 2.8 Voltage Standing Wave Ratio

2.2.3 Directivity D

Directivity D is considered as the most important and having a great significance or value. Directivity of an antenna defined as the ratio of the radiation intensity in a given direction from the antenna to the radiation intensity averaged over all directions [16]. We also know that average radiation intensity is the total power divided by 4π . This can also be written as following in equation (2.6).

$$D = \frac{U}{U_o} = 4\pi \frac{U}{P_{rad}} \quad (2.6)$$

Maximum directivity can also be expressed in the same way with having maximum radiation intensity, which is mathematically expressed as in equation (2.7)

$$D_{max} = \frac{U_{max}}{U_o} = 4\pi \frac{U_{max}}{P_{rad}} \quad (2.7)$$

$$\text{Average Radiation Density} = \frac{1}{4\pi} = U_o \quad (2.8)$$

Where as D_{max} is the maximum directivity, U_{max} is the maximum radiation intensity, U_o is the radiation intensity all direction and P_{rad} is the radiated power. For isotropic source, the directivity is unity and that is the reason we are taking it as a reference

source for further findings. Figure 2.9 is showing the directivity pattern of different antenna types.

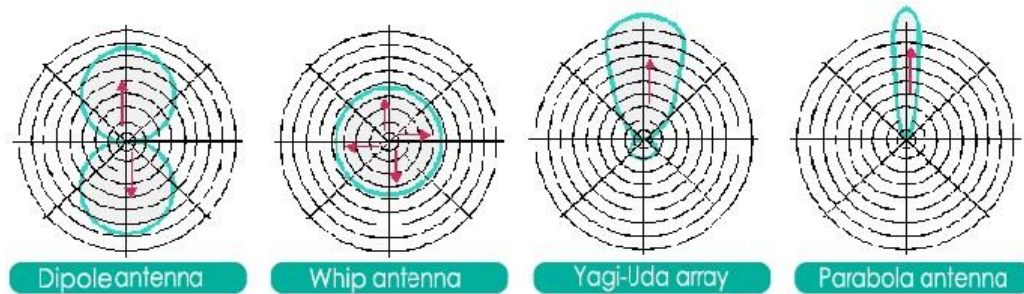

Figure 2.9 Directivity of different antenna

2.2.4 Gain G

Gain of antenna is actually describing the efficiency of antenna, as it depends on the efficiency and directivity. The better directivity will give better radiation pattern, which means that the energy is transmitted in a required direction [16] [21] [22].

Gain can be defined as the ratio of intensity in the given direction to the total input power of antenna radiated in all directions. Following equation (2.9) shows the gain. It can be represented in dB.

$$Gain = 4\pi \frac{\text{Radiation Intensity}}{\text{Total Input Power}} \quad (2.9)$$

Equation 2.10 shows us the maximum gain if we have maximum directivity

$$G_{max} = e_{max} D_{max} \quad (2.10)$$

Gain is varying with the frequency is changing can be seen in figure 2.10



Figure 2.10 Gain (dB) of Antenna

2.2.5 Radiation Pattern

Radiation pattern is defined as the representation of radiation characteristics of antenna graphically in terms of real coordinate system. It shows the distribution of antenna radiated signals in the real space. It is represented in far field most often in two dimensions or three dimensions depend on the information required. Figure 2.11 and 2.12 shows the 2D and 3D radiation pattern respectively [16].

Half Power Bandwidth (HPBW) can be find out from the main lobe of radiation pattern where it has half power (-3 dB). Also from the radiation pattern we can easily notice the major lobes and minor lobes. Major lobes are the part of pattern which contains maximum direction of radiation while minor lobes are mostly unwanted directions of radiation pattern.

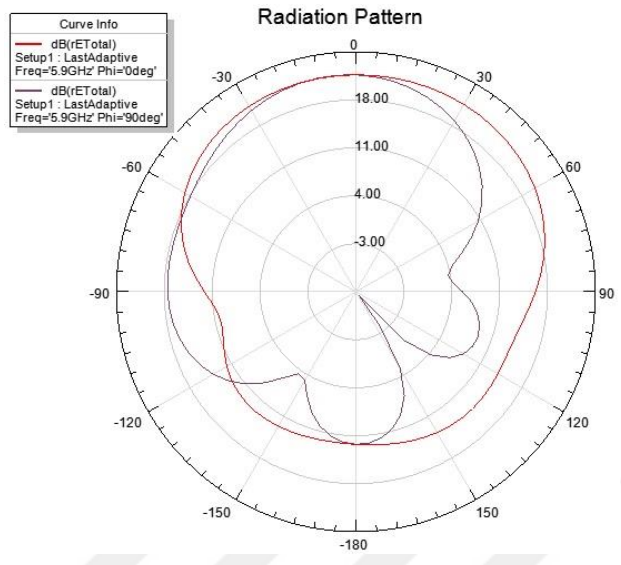

Figure 2.11 2D Radiation Pattern of Antenn

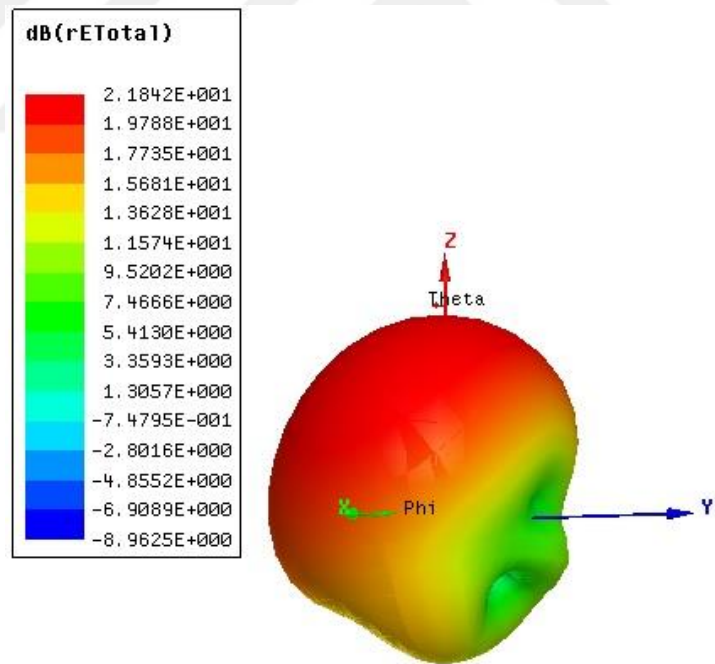

Figure 2.12 3D Radiation Pattern of Antenna

2.2.6 Radiation Intensity

Radiation intensity can be calculated from the product of radiation density and square of the distance as it is far field parameter. It is defined as the radiated power by antenna per

unit solid space and denoted by U . Formula mentioned in equation (2.11) shows us the mathematical representation of radiation intensity.

$$U = r^2 W_{rad} \quad (2.11)$$

Where r is the distance in the far field while W_{rad} is the radiation density [23].

2.2.7 Bandwidth

Bandwidth refers to the range of frequency, where antenna operates. This range defines the characteristics and their performance for specific purpose. For antennas operating in a broadband region, bandwidth is usually represented in ratio such as 10:1 which shows the maximum frequency is 10 times greater than smaller frequency. While on the other hand the narrowband region operating antenna, the bandwidth is represented in percentage [21].

2.2.8 Polarization

Polarization of the wave radiated by the antenna is the orientation of electric field at the given point. Polarization can be linear, circular or elliptical depending on the polarization pattern. The difference between the polarization of receiving antenna and the incoming wave because of polarization mismatch is refers to polarization loss [21] [22].

2.2.8.1 Linear Polarization

Linear polarization is the type of polarization in which the time phase difference between two components of propagated wave is scalar multiple of π .

$$\Delta\phi = \phi_y - \phi_x = n\pi \quad (2.12)$$

Where $n = 0, 1, 2, 3 \dots$

2.2.8.2 Circular Polarization

Circular polarization is the type of polarization in which the two component of propagated wave is same and the time phase difference is odd multiple of $\pi/2$ [24].

$$\Delta\phi = \phi_y - \phi_x = \begin{cases} +\left(\frac{1}{2} + 2n\right)\pi, & n = 0, 1, 2, \dots \text{For CW} \\ -\left(\frac{1}{2} + 2n\right)\pi, & n = 0, 1, 2, \dots \text{For CCW} \end{cases} \quad (2.13)$$

2.2.8.3 Elliptical Polarization

When the time phase difference is the odd multiple of $\pi/2$ or it is not equal to multiple of $\pi/2$ is known as elliptical polarization.

$$\Delta\phi = \phi_y - \phi_x = \begin{cases} +\left(\frac{1}{2} + 2n\right)\pi, & \text{For CW} \\ -\left(\frac{1}{2} + 2n\right)\pi, & \text{For CCW} \end{cases} \quad (2.14)$$

$$\Delta\phi = \phi_y - \phi_x \neq \pm \frac{n}{2}\pi = \begin{cases} > 0 & \text{For CW} \\ < 0 & \text{For CCW} \end{cases} \quad (2.15)$$

Where $n = 1, 2, 3, \dots$ and the ratio between major axis of the lobe and minor axis of lobe is known as axial ratio which ranges from 1 to ∞ and can be seen in equation (2.16).

$$\text{AxialRatio} = \frac{\text{MajorAxis}}{\text{MinorAxis}} \quad (2.16)$$

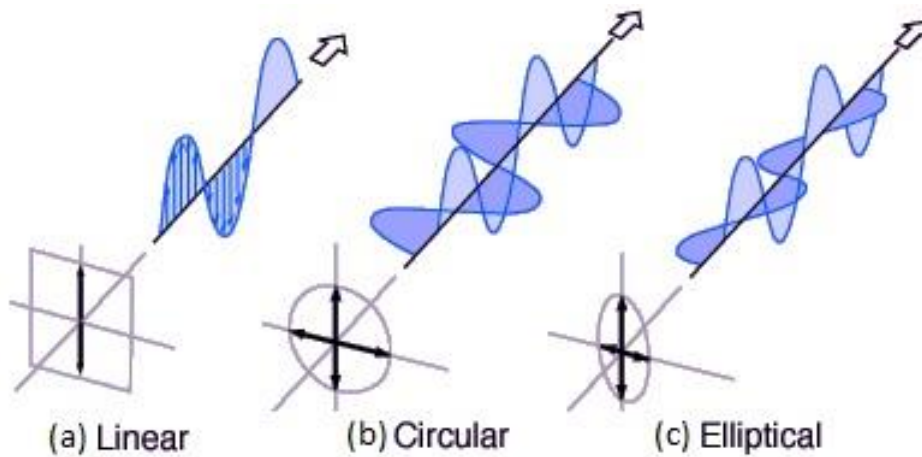

Figure 2.13(a) Linear Polarization, (b) Circular Polarization, (c) Elliptical Polarization

Figure 2.13 shows the linear, circular and elliptical polarization. In circular polarization we can see that electric field and magnetic field is perpendicular to each other.

Microstrip patch antenna is discussed in detail. This chapter includes feeding techniques such as feed line method and coaxial probe etc.



3 MICROSTRIP ANTENNA

Researchers are focusing on the different aspects of microstrip antenna because of its extraordinary advantage and applications. Microstrip antenna is one of the popular types of antenna and almost used everywhere. Patch can be printed on the low profile circuit board which is used to radiate the signals. Radiating patch is mounted on the low cost substrate with the ground on the lower side [19]. Radiating patch can be made up of conducting material such as copper or gold. Simple structure of microstrip antenna is shown in figure 3.1.

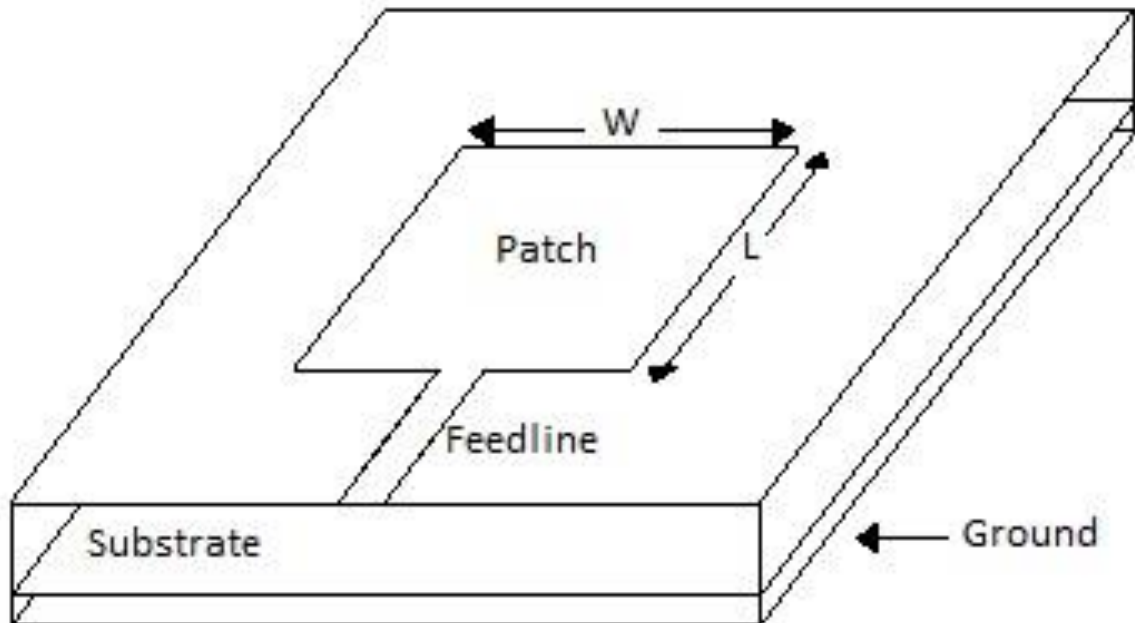

Figure 3.1 Microstrip antenna

Patch can be having different shapes according to our required application such as shown in figure 3.2

Fringing field has been radiated from the match, while patch act as resonating cavity as a result impedance matching occurs. Better efficiency will be achieved if matching occurs properly [18]. A thick substrate with a low dielectric constant is required to get a better performance of antenna. Dielectric constant, ϵ_o of substrate is usually ranges in between 2.2 to 12. Some of dielectric material is mentioned in table 3.1 [25].

Table 3.1: List of dielectric material substrate

Substrate	Relative Permittivity, ϵ_r	Dielectric Loss Tangent
Air	1	0
FR4	4.4	0.02
Teflon	2.08	0.001
Silicon	11.9	0
Rubber	3	0
PVC Plastic	2.7	0.007
Glass	5.5	0
Polystyrene	2.6	0
Quartz Glass	3.78	0
Foam	1.05	0
Roger 4350	3.48	0.004

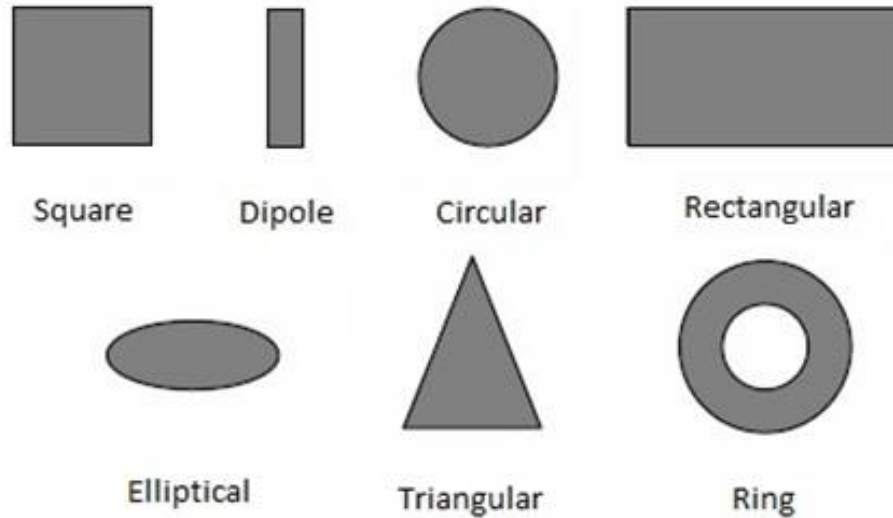

Figure 3.2 Different shapes of patch

3.1 Design of microstrip antenna

Microstrip antenna is consisting of a very simple designing as we can see in previous chapter the structure is made of three basic units which is radiating patch, dielectric substrate and ground. Radiating patch is on the upper side of the substrate while ground is on the lower side of the electric substrate [18-20].

Radiating patch is basically made up of conducting material such as gold, copper and used to radiate electromagnetic waves. The most common and easy analyzing shape is rectangular patch. The length and thickness of patch is depending on the free space wavelength. The length of patch, L is usually in between $0.333\lambda_0$ to $0.5\lambda_0$ while the thickness, t of the patch should be very less such as $t \ll \lambda_0$.

The property of dielectric substrate is also important to be in a specific range. The height, h is normally in the range of $0.003\lambda_0$ to $0.05\lambda_0$ while on the other hand, dielectric constant, ϵ_0 is in the range of 2.2 to 12. Thick substrate is used because of having less dielectric constant which makes it more efficient and larger bandwidth but it cost more with the comparison of thin substrate, which has a higher value of dielectric constant with the low efficiency and narrow bandwidth.

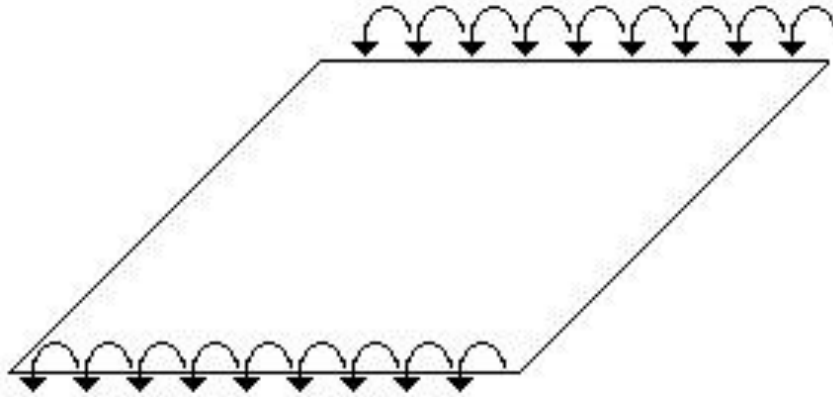

Figure 3.3 Fringing field

Single or array of microstrip antenna feed with either single or multiple lines mounted on a printed circuit board could achieve linear or circular polarization while it can be used to detection purpose because of better directivity. In figure 3.3, it can be seen that fringing field is radiated from the edges of the patch which act as a resonating cavity when impedance matches and provide better efficiency. A very little power radiates when there is lack of impedance matching. Conductivity and internal fields of the cavity is greatly affecting the radiated power from edges of the patch [26].

3.1.1 Feed technique

There are many techniques used in the feeding microstrip antenna but most of the time, four techniques are very common such as microstrip feed line, coaxial probe, aperture coupling and proximity coupling. Broadly speaking there are two division of feeding radiating patch which is contacting and non-contacting. Microstrip feed line and coaxial probe is placed in contacting while aperture coupling and proximity coupling is in non-contacting category [21] [22].

3.1.1.1 Microstrip feed line

Feed line is famous because of the simplest fabrication and easy configuration. Usually feeding line is narrow as compared to patch and can be mounted on the same surface of dielectric substrate with the patch. For matching the impedance of the feed line to the patch, we need to provide the proper inset cut and control the position [22]. Feed line can be seen in mentioned figure 3.4.

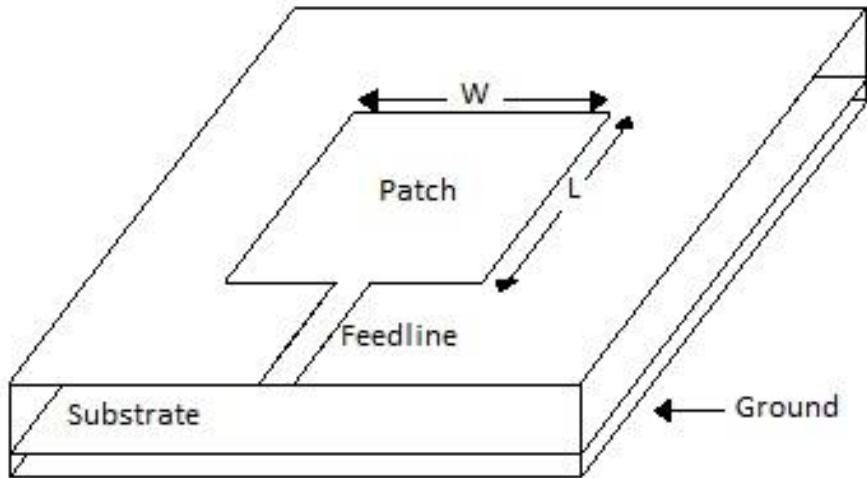

Figure 3.4 Microstrip feed Line

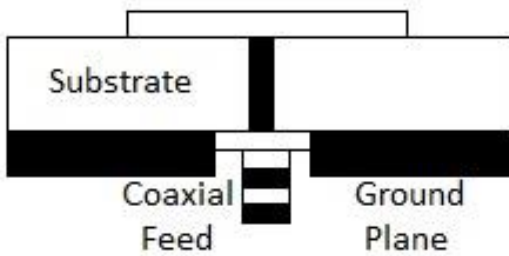
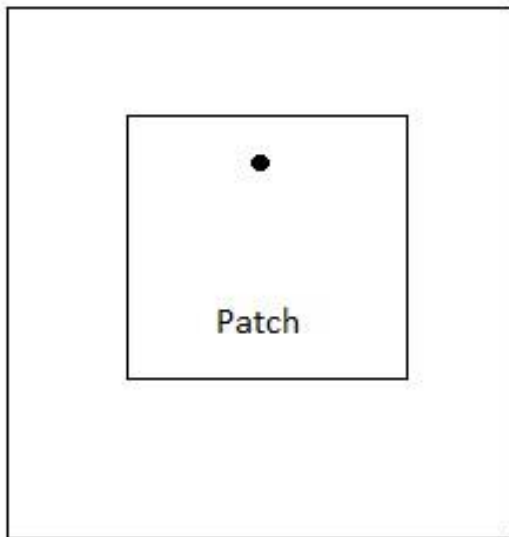

Figure 3.5 Coaxial probe feeding technique

3.1.1.2 Coaxial probe

Coaxial probe feeding method is considered as a famous technique because of its wide use. The conductor inside the probe is connected to the radiating patch by passing through the substrate. This feeding method provides a narrow bandwidth as well as is difficult to fabricate if we have a thick substrate, which is considered a drawback. While on the other hand, we can place it at any position for getting better impedance matching and it has low unwanted radiations [22]. Figure 3.5 shows us the simple structure of a coaxial probe.

3.1.1.3 Aperture coupling

It consists of two substrates with ground in the middle. There is a feed line which is coupled with the patch through the slot. The slot is on the ground plane used for coupling the patch and feed line. Usually, a substrate having a low dielectric constant is placed on top, while the substrate having a high dielectric constant is placed in the bottom.

A ground plane is placed in between two substrates to avoid interference and provide better polarization as it is visible in Figure 3.6. Also, the values of dielectric substrate, position and size of slot, and measurement of feed line are important to get an enhanced design. It has a narrow bandwidth and is the most difficult fabrication method [22].

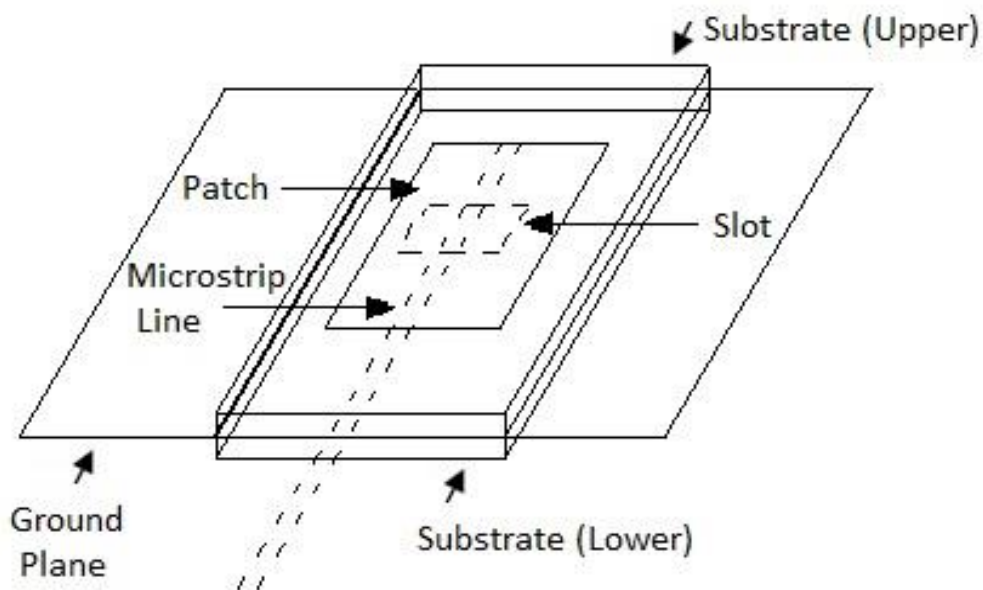

Figure 3.6 Aperture coupling feeding technique

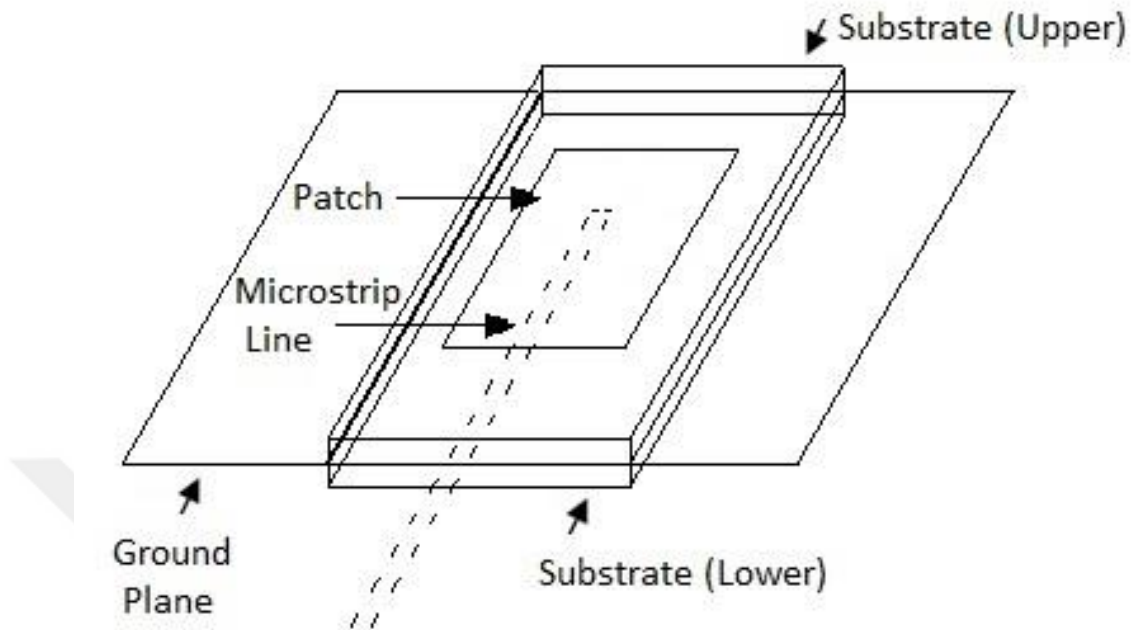

Figure 3.7 Proximity coupling feeding technique

3.1.1.4 Proximity coupling

Proximity coupling is also known as electromagnetic coupling. It uses the two substrates with the radiating patch on the top of upper substrate. Feed line is in between the two substrates, which controls the matching impedance with the varying values of length and width. The thickness of substrate is increased in this method which enhanced the bandwidth up to 13%. Fabrication is much difficult as compared to other techniques also the thickness of antenna is increased [16]. Proximity coupling feeding techniques is mentioned in figure 3.7.

3.2 Properties

Microstrip antenna has many advantages over other antennas because of having low profile fabrication, low cost, small size. It is also known as planer antenna because of having flat structure. Antenna's radiating patch is mounted on printed circuit board (PCB) which is basically a substrate material. Usually patch is printed on one side while ground is on other side but it can be on the same side which is known as co-planer antenna [23][27].

This distance between patch and ground is known as height, denoted by h , which greatly affect bandwidth efficiency. By increasing the thickness of substrate will enhance gain but it creates surface wave excitation will cause the unwanted radiation and reduce the effectiveness of antenna. For better front to back ratio we should increase the size of ground as compared to patch. It should be increase two or three times of patch size for improved operation. Increasing the size of ground plane cause increase in gain but it is very little because of less diffraction on the edges [18].

Electrical field is having maximum value on one side of the patch while simultaneously it will be minimum value on another side and zero in the centre point of patch. Maximum and minimum values of electric field are consistently changes with change of phase of signal. It will be maximum and minimum with the change of phase of electric field. On the edges of the patch, electric field does not stop suddenly. It leak out from the edges and extend outwards known as fringing field which is the reason of radiation from the patch. The basic concept behind the rectangular patch is cavity leakage and mode using this concept is TM [21].

TM is considered as the magnetic field distribution between patch and ground is represented as TM_{nmp} , where p is the direction of field changed in z -axis and almost negligible while n and m is representing the variation in x and y direction.

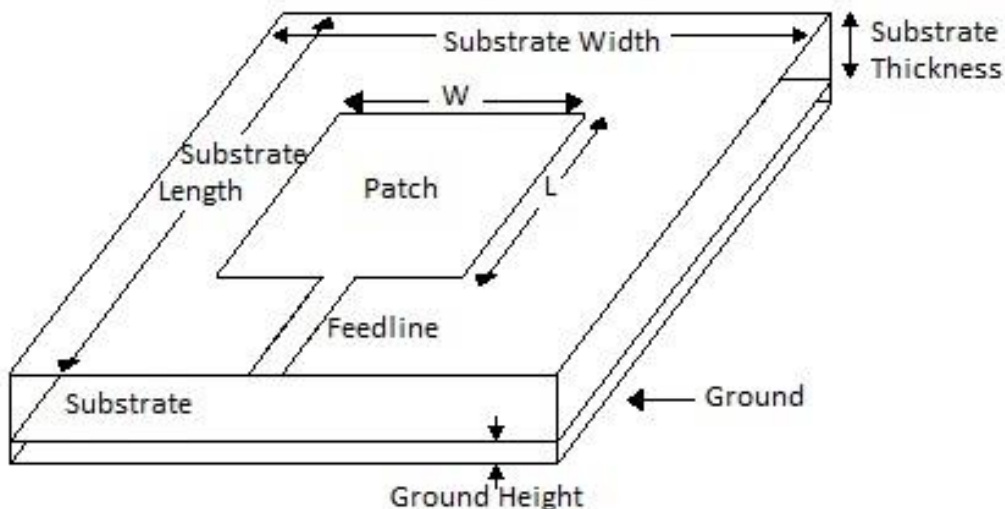

Figure 3.8 Dimensions of simple rectangular microstrip patch antenna

3.2.1 Dimension

Resonating length is important to be kept under specific range, as we can see from equation 3.1; it clearly shows the relationship between length, wavelength in free space and dielectric constant of the dielectric material [20].

$$L = 0.49 \frac{\lambda_o}{\sqrt{\epsilon_r}} \quad (3.1)$$

Ground size, thickness of dielectric material and width of radiating patch is also affecting the resonating frequency but not as much as wavelength and dielectric constant. Detailed dimension can be seen in figure 3.8 where we can see ground size, length and width etc.

3.2.2 Impedance Matching

Impedance matching plays a very important for better distribution of electric field and current all along the radiating patch, as mentioned in figure 3.9, to get an improved radiation. The measuring parameters and position has a great impact on the enhancement of impedance matching.

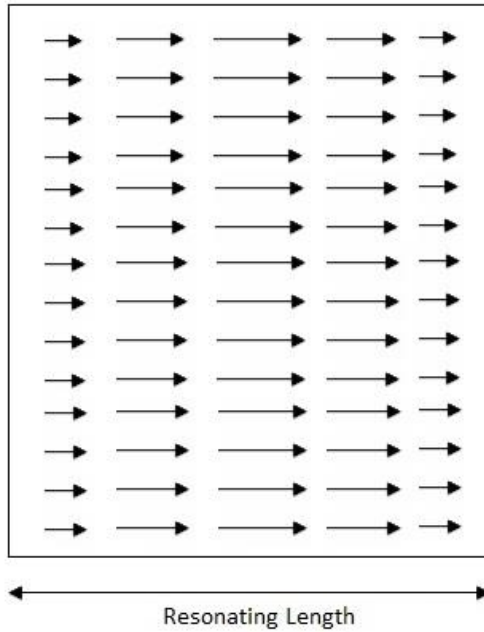

Figure 3.9 Flow of current in resonating length

If we see from figure 3.10 the current and electric field changes in the patch, it can be seen very clearly that the current is minimum at the edges and maximum at the centre of the patch, while on the other hand electric field is maximum at left edge, minimum at right edge and zero at the centre of the patch. Impedance also depend on the width of the patch, by increasing the width will cause decrease in the impedance. In short, we can modify the width of the patch to get impedance as per our requirement [28].

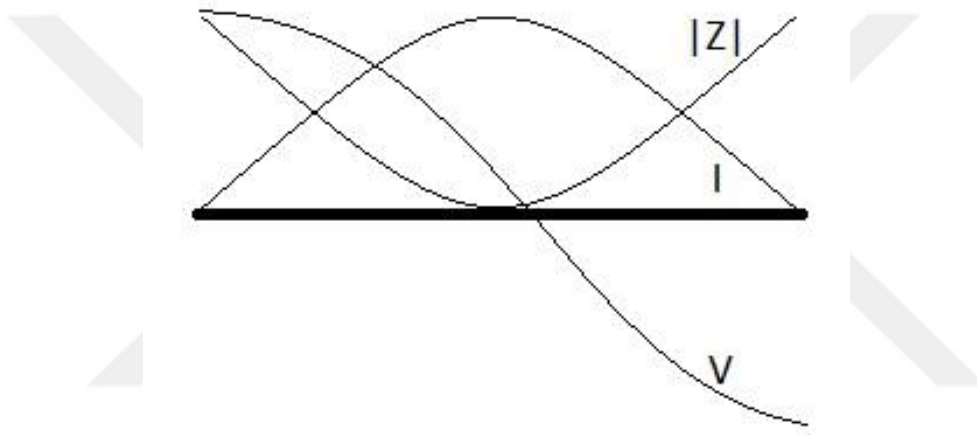

Figure 3.10 V, I, $|Z|$ Distribution along resonant length

3.3 Coplanar Waveguide (CPW)

Coplanar waveguide (CPW) was fabricated by C. P. Wen in 1969, after successful fabrication it becomes very popular in microwave integrated circuits (MICs) [27]. CPW is typically consists of strip with ground on both side and mounted on the same plane of substrate as shown in figure 3.11. It has many advantages over other microstrip line because of easy fabrication and low radiation loss.

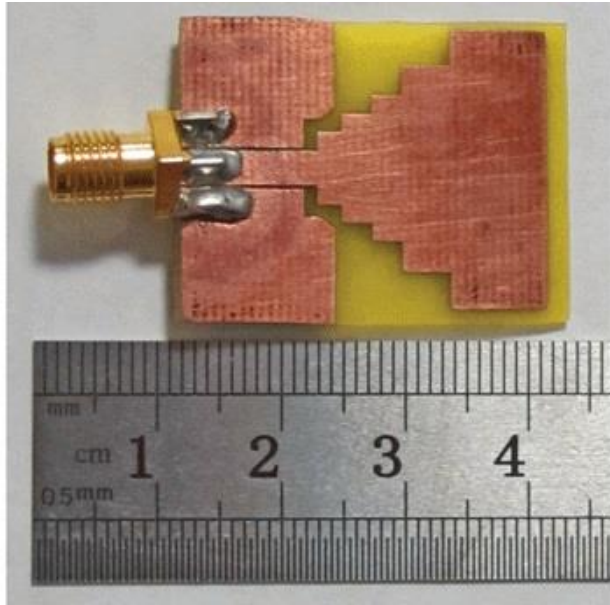

Figure 3.11 Coplanar waveguide antenna

Coplanar waveguide can be used in printed antenna by increasing the width of strip. This wider strip can be used as radiate a microwave signals. This can help to get linear polarized pattern. CPW antenna has better gain and low cross polarized radiation. It can help to reduce the size of printed antenna as produce a very compact design [23].

In the end, we concluded from this chapter about designing and properties of microstrip antenna with different feeding techniques. We can say that it is the simple structure with a lot of advantages over other antennas. This is the reason which make it more useful and almost use everywhere in compare of other antennas. In chapter 4, we will discuss about the proposed work. Chapter includes designing, computation, simulation, results and application in detail.



4 PROPOSED WORK

This chapter is basically including proposed work of UWB microstrip antenna designing for microwave imaging systems. Ultra-wide band usage for microwave imaging purpose can be seen in detail, which is achieved from a simple microstrip antenna with the enhanced gain and return loss. UWB antenna is becoming popular among researcher for having extra ordinary applications such as microwave imaging purpose, radar systems, measurement and communication systems [29]. Ultra-wide band region is in between 3.1 GHz to 10.6 GHz according to federal communication commission in 2002, which is based in America. This range, identified by the commission, guides us to focus on the specific range with the improved gain and compact size of antenna. We will be focusing on the microwave imaging purpose used for medical applications for example tumor detection. As compare to other process for detection of cancerous tissues from human body is not so efficient because of low sensitivity and slow process such as MRI etc. MRI is basically magnetic resonance imaging which needs huge machinery with high frequency radio signals. Comparatively microwave imaging is a safe and high sensitive process for detection purpose which makes it more popular as compare to other processes. Institute of electrical and electronics engineering (IEEE) defined the safety measures for maximum exposure of a body to microwave signals and their absorption rate as discussed in chapter 1.

Minimum absorption rate is depending on energy of the signal, volume of the tissues and density of the absorbing body. There is direct relationship between energy of the signal while inverse relation of the exposed tissue volume and density of the absorbing body. Thus, we can clearly see that it keeps required energy level while using in detection of cancerous tissues [5].

This chapter includes the brief introduction of high frequency structural simulator (HFSS) after this; we discussed the designing steps in simulator software. Further there is detail explanation of designing proposed antenna. In the last section, we include all the results such return loss, VSWR, gain and radiation pattern.

4.1 High Frequency Structural Simulator (HFSS)

Every modal which is designed virtually in simulation software makes easy for researchers and students in terms of understanding and cost. High frequency structural simulator software is used in our thesis for designing antenna modal and observes the results and figures. It is user friendly with a very easy interface and easily available for students as it is open source library [30]. Interface can be seen in figure 4.1.

Project manager contain different details such as project file, boundaries, excitation data and results etc. Properties shows the property of designed structure while from the tools we can use different drawing tools and shapes to draw the as per our requirements. In short, high frequency structural simulator (HFSS) is very simple and efficient software for designing and optimization purpose.

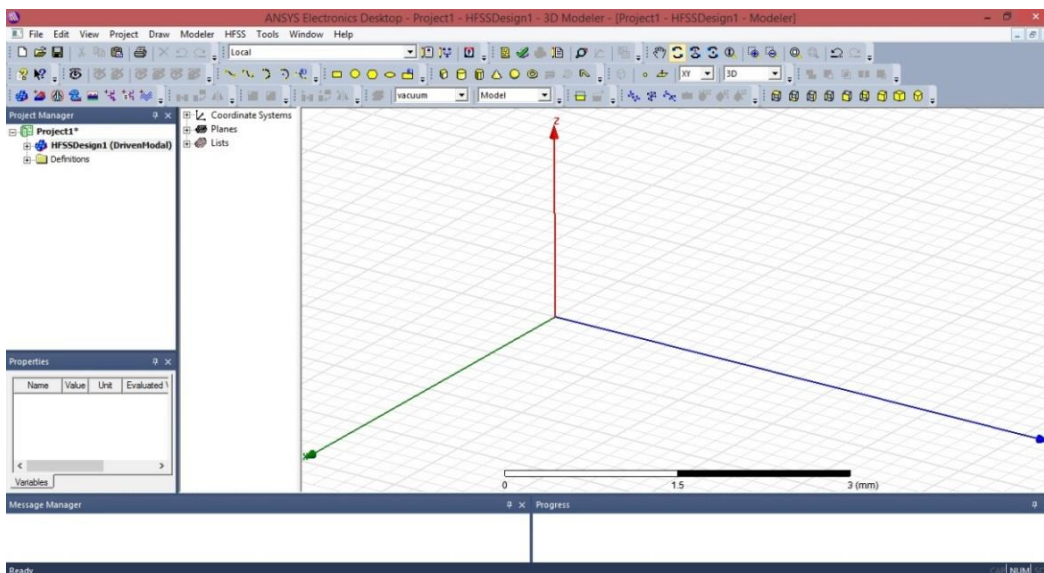

Figure 4.1 High Frequency Structural Simulator Interface

4.2 Design of proposed antenna

In this section, we will discuss the designed antenna in detail. By adding different element in patch makes a huge difference in frequency range and gain of antenna which is mentioned in this chapter. Proposed antenna patch includes stubs, circular hole in patch and inset feed line to get a required application [24]. Design parameter can also be seen in this section in detail.

Microstrip antenna is consisting of radiating patch and feed line which is mounted on the substrate. Substrate used in this antenna is FR4 with the thickness of 1.6 mm which is low cost and easily available everywhere having relative permittivity, ϵ_r of 4.4 and loss tangent, δ equals to 0.02.

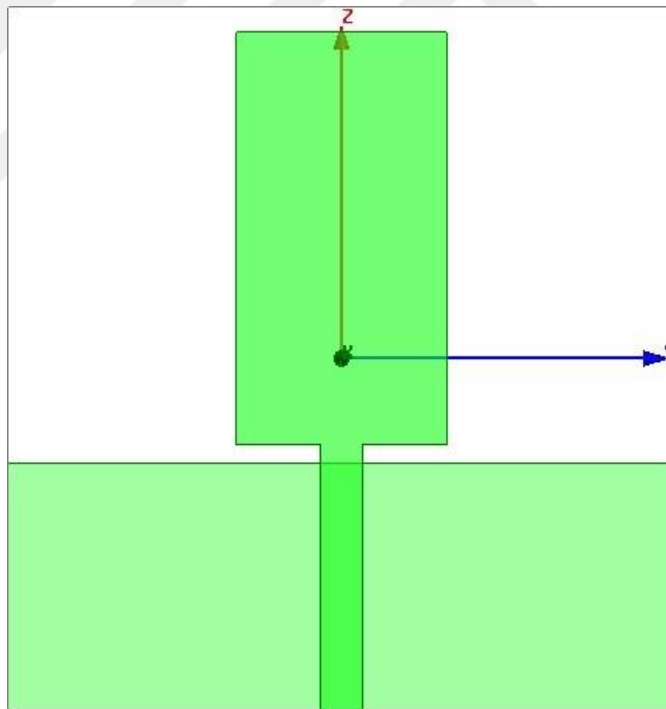

Figure 4.2 Simple design of proposed antenna

Simple design of proposed antenna is shown in figure 4.2 which is only consist patch excited with the feed line on the upper side of substrate while ground on the lower side of the substrate. Length of substrate is denoted by L which is equal to 40 mm while width of the substrate which is denoted by W is 38 mm. Relative permittivity is the

ability of a material to store electrical energy in electric field while the thickness of material directly affect the bandwidth of antenna [25].

After introducing inverted L shaped slit and I shaped stub in the ground makes return loss less than -10dB with a little improvement from simple design of antenna [31]. Length of radiating patch, L_p is 23.5 mm while width is 12 mm which is mounted on the upper side of substrate. The length of feed line is 15.1 mm while width is 2.4 mm which provide 50Ω impedance.

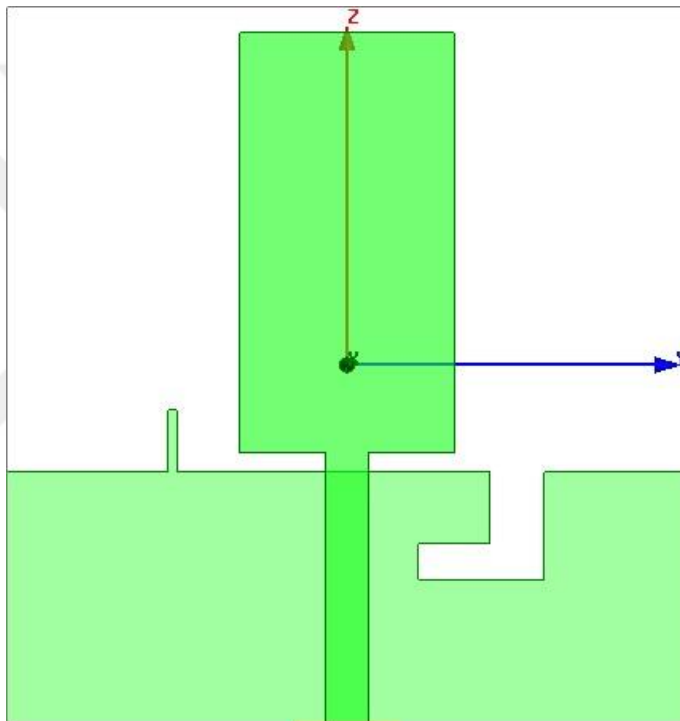

Figure 4.3 I Stub and Inverted L slit in ground

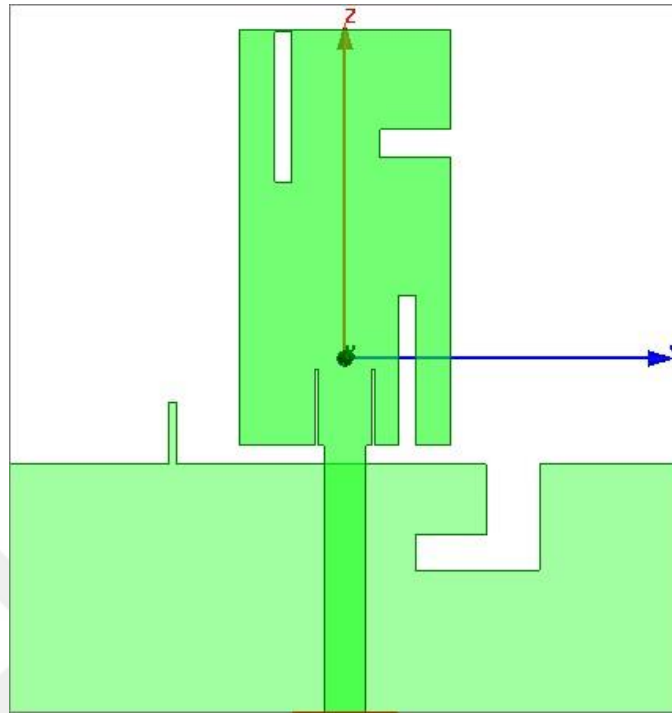

Figure 4.4 Inset-feed and slits in patch

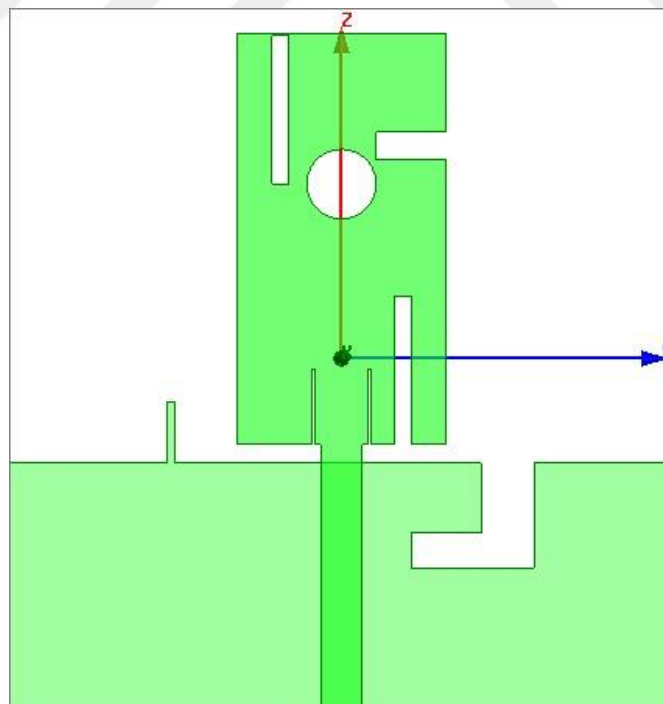

Figure 4.5 Circular shape hole in centre of patch

Table 4.1: Values of antenna parameters

Parameter	Values	Parameter	Values	Parameter	Values
L	40 mm	W ₃	4 mm	W ₈	0.2 mm
W	38 mm	W ₄	8 mm	L ₉	16.3 mm
Height	1.6 mm	L ₅	8.5 mm	W ₉	2 mm
L _g	14 mm	W ₅	1 mm	L ₁₀	2.3 mm
L ₁	3.5 mm	L ₆	8.5 mm	W ₁₀	3 mm
W ₁	0.5 mm	W ₆	1 mm	L _f	15.1 mm
L ₂	6 mm	L ₇	1.6 mm	W _f	2.4 mm
W ₂	3 mm	W ₇	4 mm	L _p	23.5 mm
L ₃	2 mm	L ₈	4.3 mm	W _p	12 mm

4.3 Results

4.3.1 Return loss

Return loss is the most important parameter as discussed in chapter 2; it is the power loss in the signal, which is reflected back because of lack of coherence in the transmission line, is known as return loss. This lack of coherence occurs by the mismatching of transmission line and antenna [16] [21] [22].

From figure 4.7, it is very clear that without any slit and stub, return loss is not as impressive as the operation range is from 2.6 GHz to 3.7 GHz and from 5.7 GHz onward. Graph of figure 4.8 shows the return loss of antenna having I shaped stub and inverted L shaped slit which operated in the region 2.4 GHz to 3.4 GHz and 7.4 GHz onwards. While in the next figure 4.9, return loss is more likely as the propose antenna which is from 2.1 GHz to 7.6 GHz but there is considerable difference in gain of both antennas which is shown in next section.

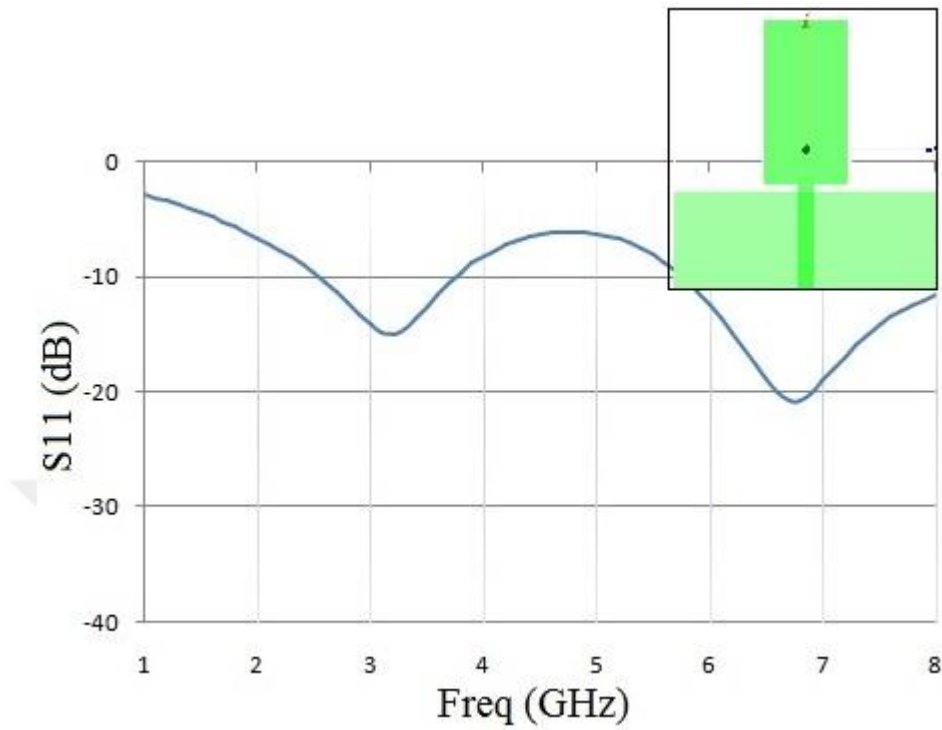

Figure 4.7 Return loss (dB) of simple design of proposed antenna

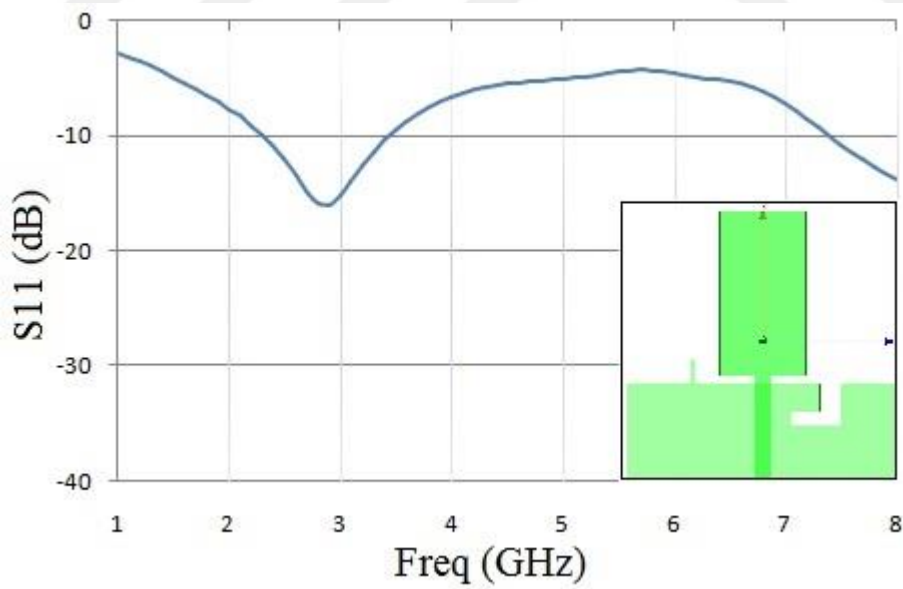

Figure 4.8 Return loss of antenna with I stub and Inverted L slit in ground

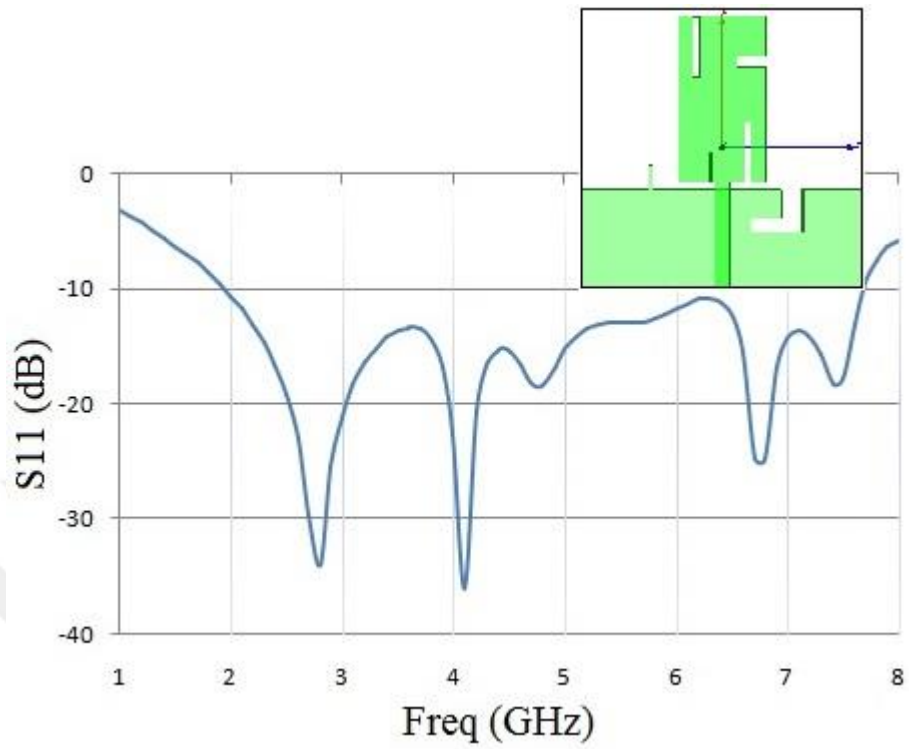

Figure 4.9 Return loss with Inset-feed and slits in patch

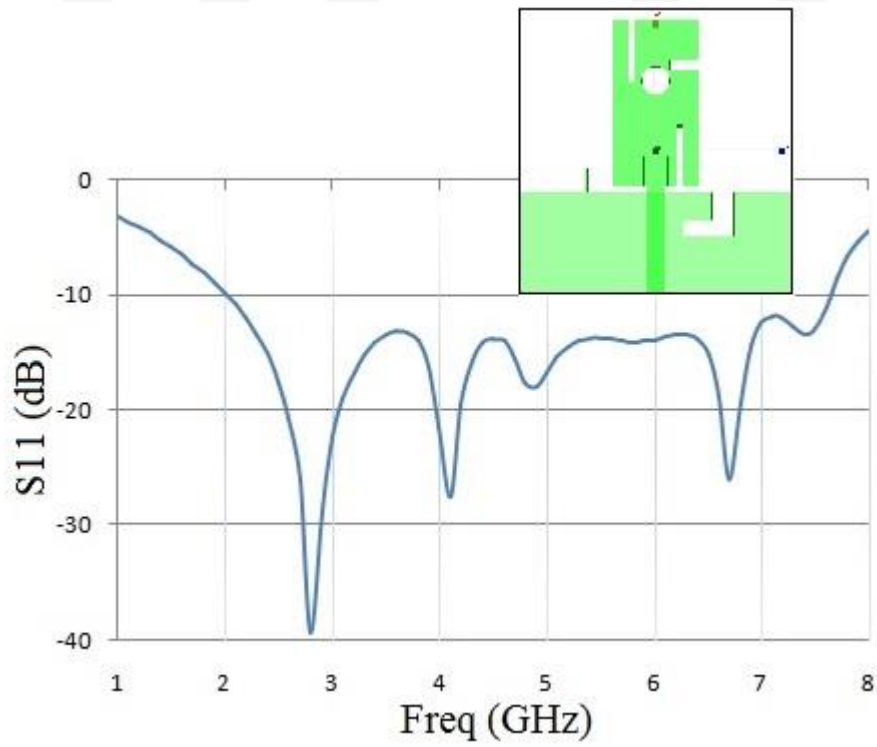

Figure 4.10 Return loss of proposed antenna

Return Loss, S11 of proposed antenna is ranges between 2.01 GHz to 7.64 GHz which is ultra-wide band antenna and comparatively much better results used for microwave imaging systems with the fractional bandwidth of 116%.

Figure 4.11 shows the variation occur in return loss of antenna while changing ground and radiating patch as it can be seen that the (d) antenna is having better return loss comparatively.

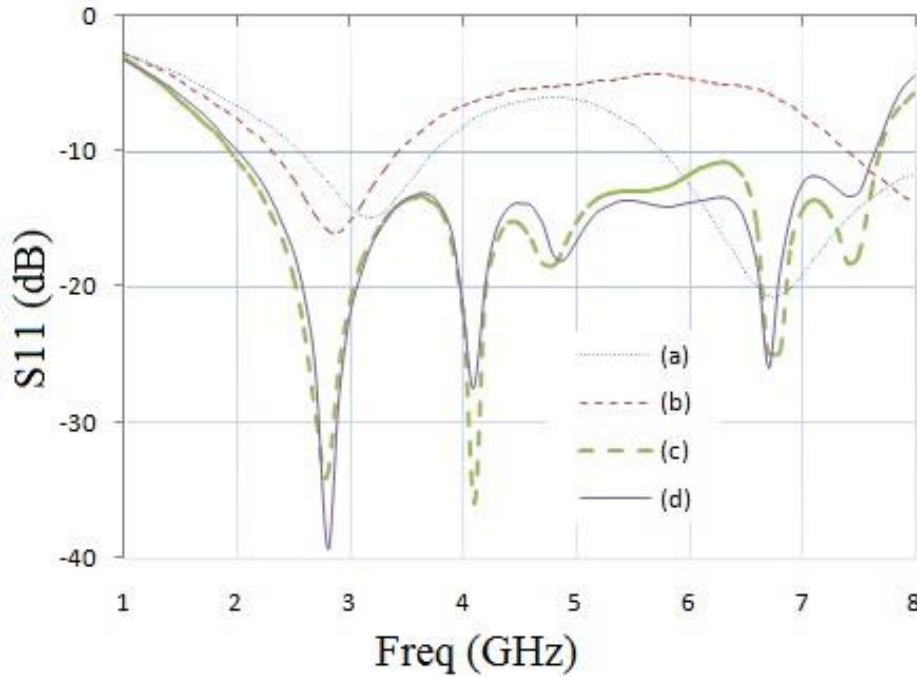

Figure 4.11 Return Loss of antenna (a) Simple design of proposed antenna (b) Stub and Inverted L slit in ground (c) Inset-feed and slits in patch (d) Circular shape hole in centre of patch

4.3.2 Voltage Standing Wave Ratio

Voltage standing wave ratio, VSWR should be less than 2 which depend on the return loss as its formula is mentioned in previous chapter. VSWR is basically representing the ratio therefore there is no unit. We can see the VSWR where antenna operates is started from 2 GHz to 7.6 GHz is less than 2 [22]. Equation (4.1) shows us the relationship between VSWR and coefficient ratio.

$$VSWR = \frac{1 + |\Gamma|}{1 - |\Gamma|} \quad (4.1)$$

From figure 4.12 to 4.15, there is separate voltage standing wave ratio of antenna which was designed first and then moved toward the final shape. In the end when we included the circular shape hole in the radiating patch increase the gain dramatically this can be seen in next section.

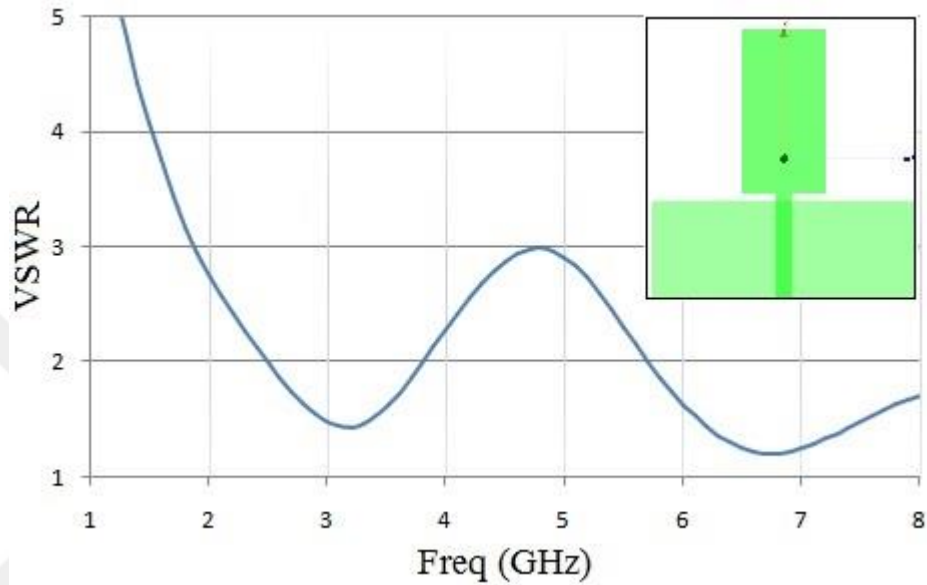

Figure 4.12 VSWR of simple design of proposed antenna

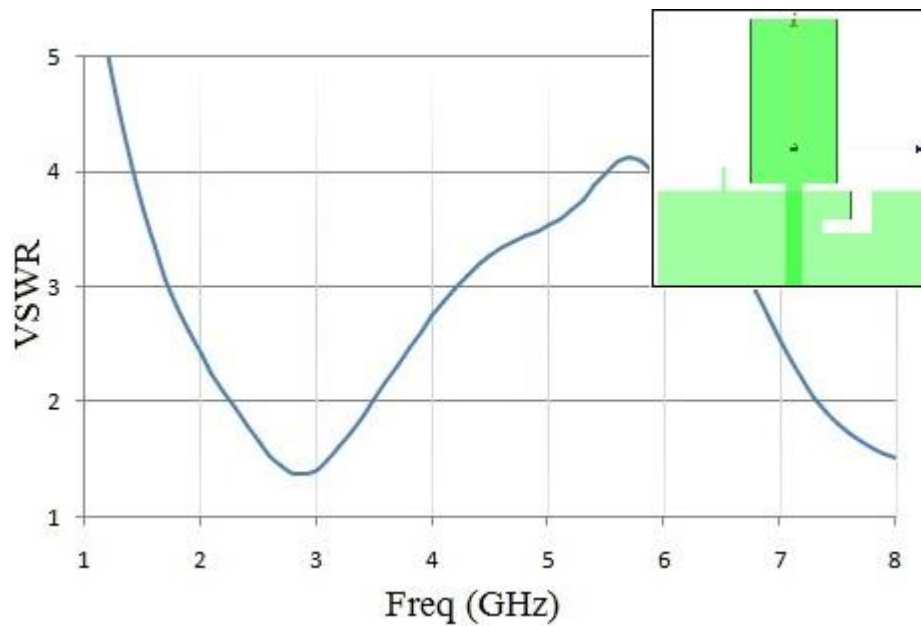

Figure 4.13 VSWR of antenna with I stub and Inverted L slit in ground

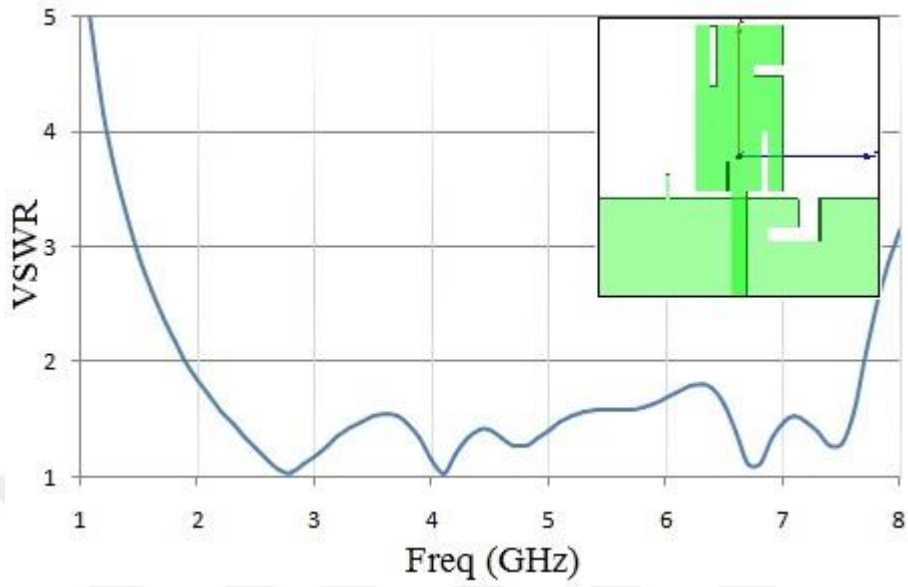

Figure 4.14 VSWR with Inset-feed and slits in patch

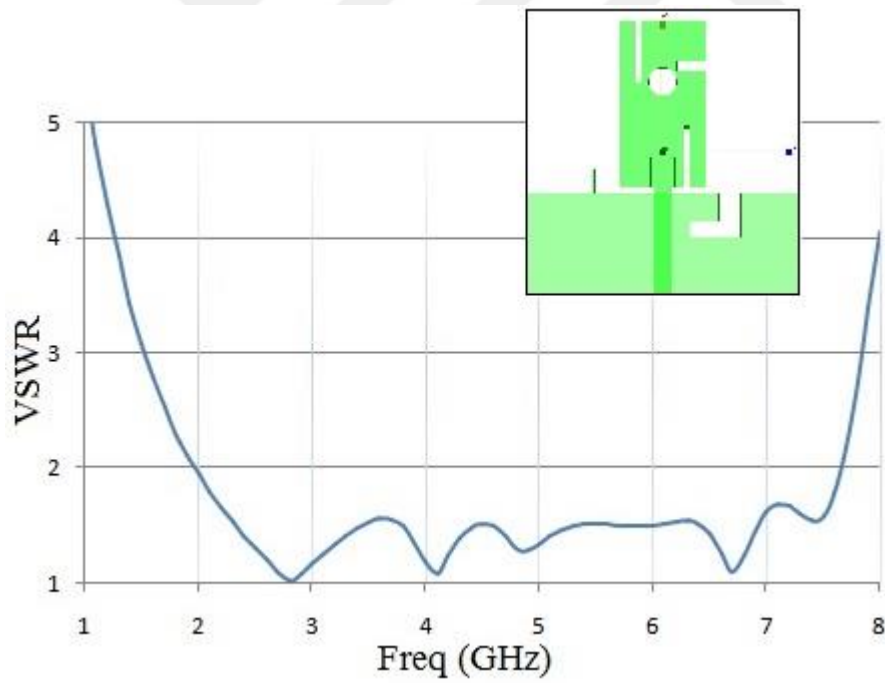

Figure 4.15 VSWR of proposed antenna

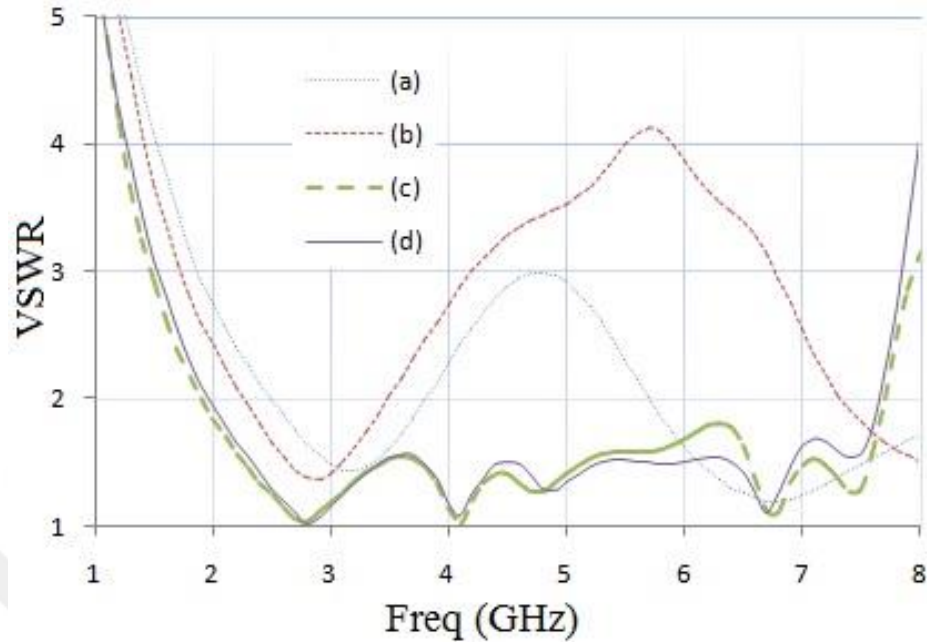
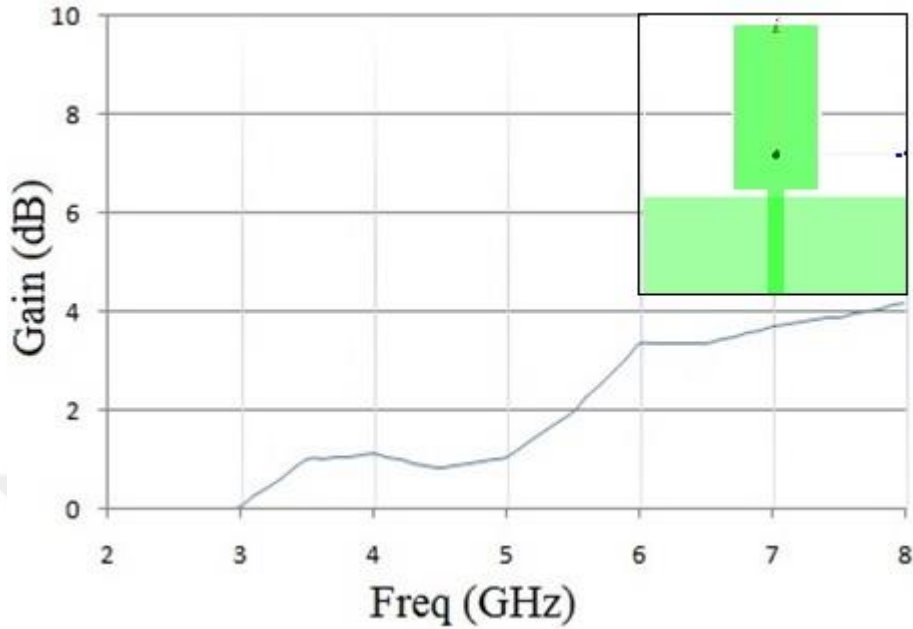

Figure 4.16 VSWR of of antenna (a) Simple design of proposed antenna (b) Stub and Inverted L slit in ground (c) Inset-feed and Slits in patch (d) Circular shape hole in centre of patch

We compared the voltage standing wave ratio which can be seen in figure 4.16. In the end, we added the circular hole in radiating patch to reduce the size which is improved as compare to others.

4.3.3 Gain of propose antenna

Microwave Imaging requires a high gain antenna which is useful in detecting cancerous tissues. It plays a vital role in detection process as it is directly related to human body there we need a better and efficient antenna [32-36]. Proposed antenna is a very simple microstrip antenna with the high gain of 9.40 dB. Figure 4.17 include the gain of antenna which is consisting of simple patch. As we can see that that gain is nearly 4 dB.



6

Figure 4.17 Gain of simple design of proposed antenna

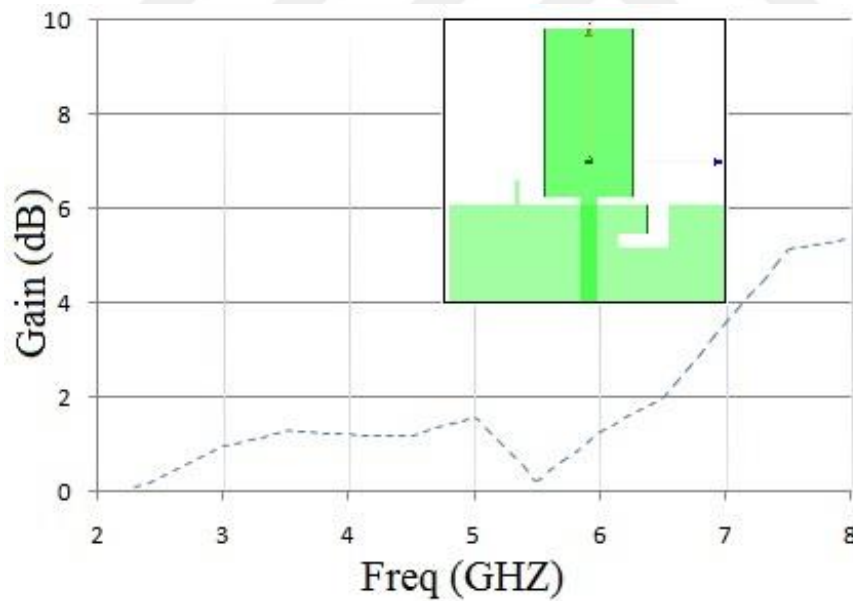

Figure 4.18 Gain of antenna with I stub and Inverted L slits in ground

While there is difference in gain in figure 4.18 but peak value is not enhanced after altering the ground. But the combine effect of antenna has been changed as we include slits in patch. Gain is improved in figure 4.19 as well as the bandwidth of antenna also enhanced.

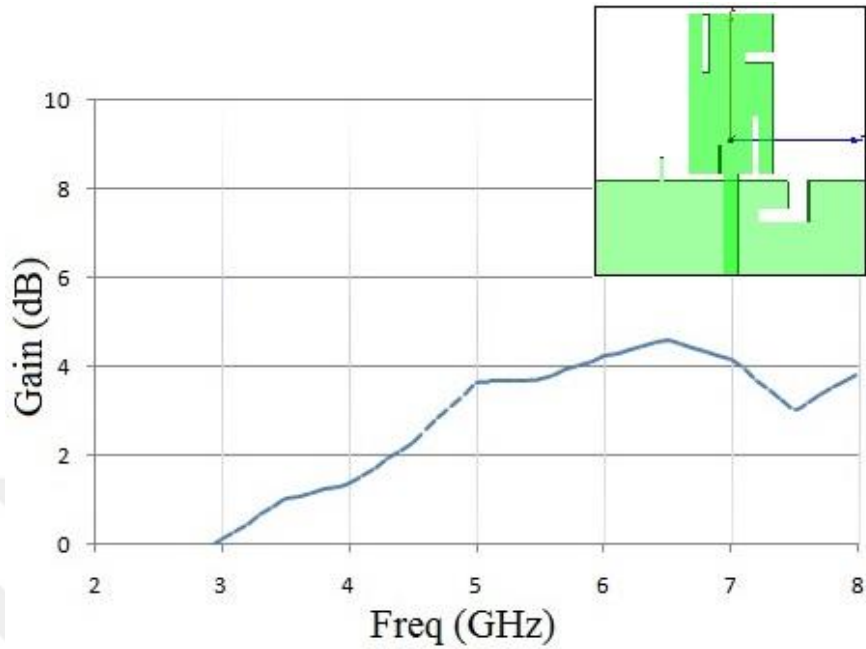

Figure 4.19 Gain with Inset-feed and slits in patch

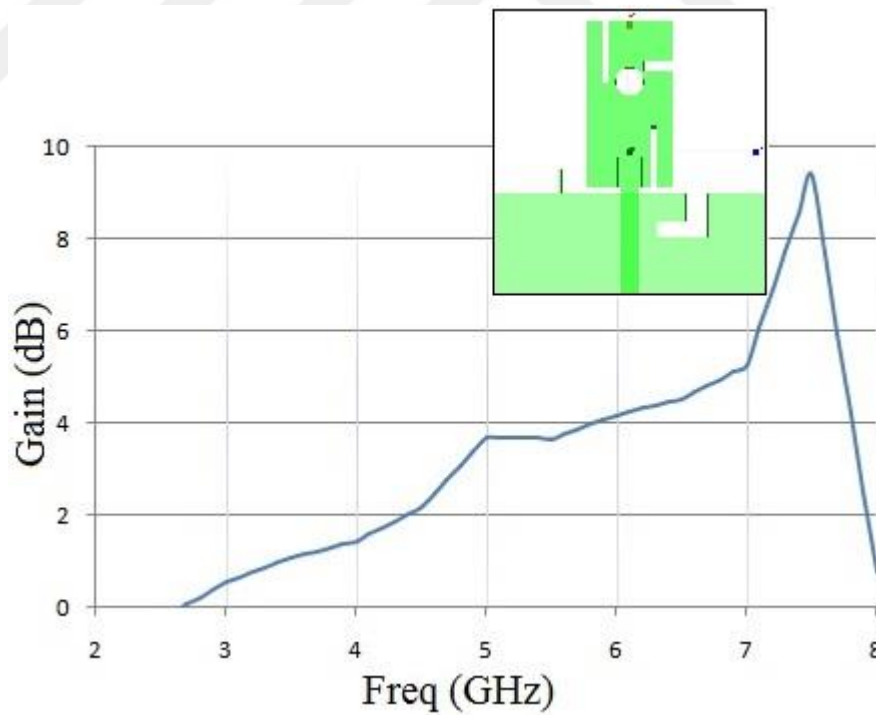

Figure 4.20 Gain of Proposed Antenna

Figure 4.21 include the gain of antenna (a), (b), (c) and (d) in one figure which shows us the variation happen in the changing design of antenna. Including circle in the center of

patch reduce the volume of patch without disturbing the current conducting efficiency [41].

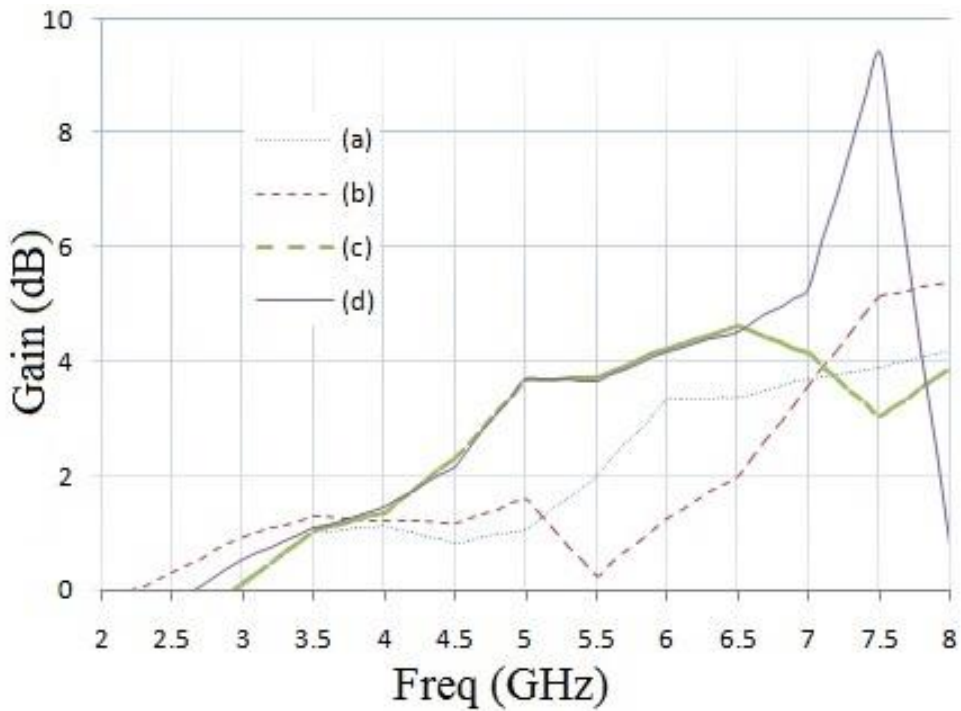

Figure 4.21 Gain of antenna (a) Simple design of proposed antenna (b) Stub and Inverted L slit in ground (c) Inset-feed and slits in patch (d) Circular shape hole in centre of patch

4.3.4 Radiation pattern

Radiation pattern of proposed antenna is important to be discussed in two dimensional and three dimensional plots to understand easily. In microwave imaging, malignant tissues are on a specific point of human body which needs to be detected through directive antenna [8]. Malignant tissues are basically different in terms of conductivity and dielectric constant which can be find out and located within the body. Figure 4.22 shows us the two dimensional radiation patterns at frequency of 5.9 GHz at θ equals to 0° and 90° and $\phi = 90^\circ$ while figure 4.23 shows us the three dimensional radiation patterns of proposed antenna

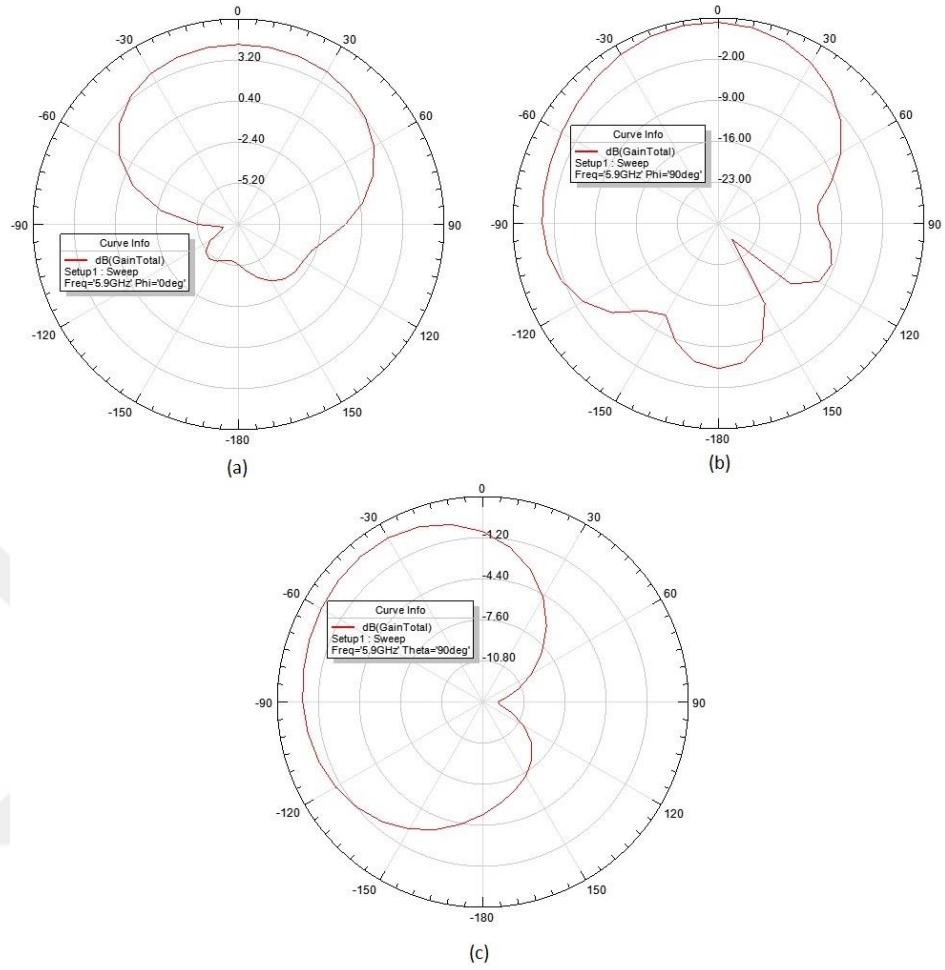

Figure 4.22 2D representation of radiation patterns (a) $\Phi = 0^\circ$, (b) $\Phi = 90^\circ$, (c) $\Theta = 90^\circ$

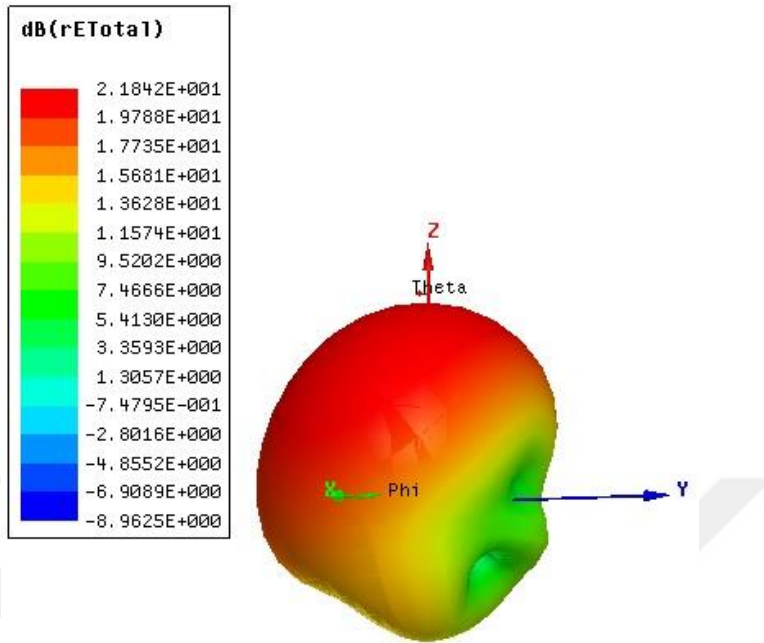

Figure 4.23 3D representation of radiation patterns

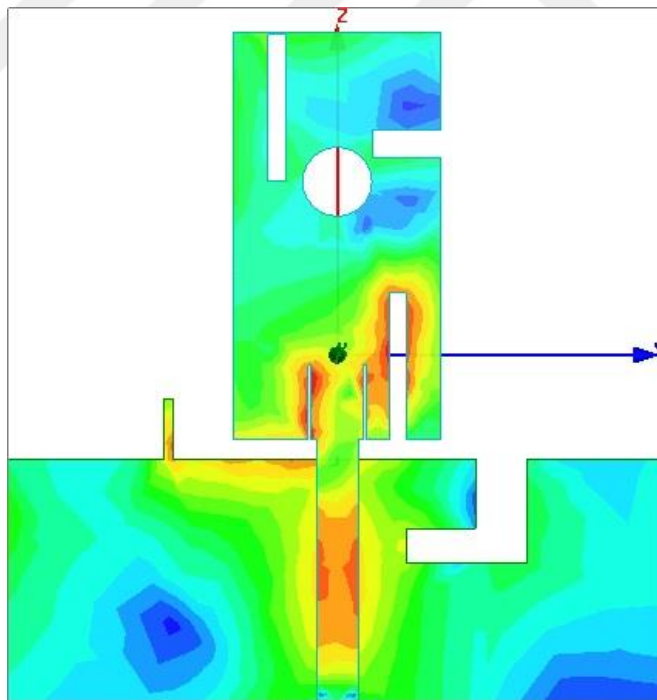

Figure 4.24 Current distribution in proposed antenna

As it is visible from figure 4.24 that current distribution is collected near feedline and ground because of capacitance created at this point. In references, there are few antennas which are compared with our proposed antenna in terms of dimensions and the operating

frequency range which is listed in table 4.2. In table 4.2, it can be seen very clearly that if antenna has high gain, it can also have a large size which is trade off. If we reduce the size, there can be reduction occur in gain. Comparatively, if we look at proposed antenna, the size and gain is enhanced with a very compact size. It may be affected by increasing the substrate dimensions such as length, width and thickness. In the third column the fractional bandwidth is also highlighted for better understanding the efficiency of antenna.

Table 4.2: Proposed antenna dimension comparison with reference antennas

References	Dimensions (mm ³)	Freq Range (GHz)	Gain
[32]	35×30×1.6	3.2–15.7 (132%)	7.5 dB
[33]	50×50×1.6	3.1–11 (112%)	9dB
[34]	35×30×1.6	3.2–12 (115.7%)	5 dB
[35]	34×36×1.6	4.6–9.6 (70%)	5 dB
[36]	50×30×1.57	4.8–6.1 (23.8%)	11 dB
Proposed Antenna	38×40×1.6	2.01–7.64 (116%)	9.39 dB



5 CONCLUSION

In the end, we conclude the thesis with a very brief conclusion. As it can be seen from previous chapters, which consist of very brief introduction of antenna and their application such as microwave imaging, mobile communication etc. Further we discussed the different types of antennas such as wired antenna, aperture antenna, lens antenna and microstrip antenna etc. Every antenna has their own advantage and disadvantage in terms of size, cost, gain, and bandwidth. Microstrip antenna is one of the most efficient antennas as it has small size and low manufacturing cost with a better gain. It can be used for single band, dual band and multiband frequency operation.

Microwave Imaging is basically the technique which uses specific range of frequency for detecting cancerous tissue in human body. Ultra-wide band antenna used for microwave imaging must have enhanced gain and directivity. According to Federal Communication Commission Report, frequency band used in microwave imaging for medical systems must be operated in 3.1 GHz to 10.6 GHz. While according to European Telecommunications Standards Institute (ETSI), frequency ranges from 3.4 GHz to 8.5 GHz. Cancerous tissues inside human body has different electrical properties as compare to normal tissues. After transmitting electromagnetic wave from malignant tissues will face different conductivity and dielectric parameters as compare to normal tissues which leads us to detect the position of cancerous tissues inside human body. According to the patients, these techniques are not so difficult and time consuming as compare to other techniques such as MRI etc. Human health and safety is also important as there is direct exposure of human body to microwave signals.

Proposed antenna, which is basically a simple designed microstrip patch antenna simulated in high frequency structural simulator (HFSS), operates in the ultra-wide band ranges from 2.01 GHz to 7.64 GHz. Substrate dimension consist of $40 \times 38 \text{ mm}^2$ with

the thickness of 1.6 mm. In the beginning we designed a simple patch to observe the radiation characteristics. Further we introduced the inverted L shaped stub and small slit in ground to improve the bandwidth. Comparatively better and improved results were produced after adding stubs and circular hole in radiating patch.

Basically it is small in size and a very compact antenna with improved gain. Gain of propose antenna is 9.40 dB, which is considerably a better results and can be used for medical purpose. Length of patch, L_p is equals to 23.5 mm while width is 12 mm with stubs and circular hole on the patch. Stubs are used to improve the gain of antenna as there are sharp edges to equally distribute current on the different points of radiating patch. Feed line technique is used to provide 50Ω impedance to the patch having length, L_f equals to 15.1 mm and width, W_f 2.4 mm. In short, a very compact size antenna is designed with enhanced and efficient performance such as breast cancer detection.

For future work, there is possibility to increase the gain and bandwidth with the decrease in size of proposed antenna, which can be used in very low profile systems. As ultra-wide band antenna has high efficiency in terms of data transmission rate while is quite helpful in communication systems.

REFERENCES

- [1] American Cancer Society. *Breast Cancer Facts & Figures 2015-2016*. Atlanta: American Cancer Society, Inc. 2015
- [2] Federal Communications Commission. "FCC Report and Order for Part 15 acceptance of ultra wideband (UWB) systems from 3.1–10.6 GHz." *FCC, Washington, DC* (2002).
- [3] European Telecommunications Standards Institute (ETSI), Ultra Wideband (UWB) technologies for communication purposes, ETSI EN 302 065 V1.1.1 (2008 02), February 2008.
- [4] Chen, Zhi Ning. "UWB antennas: Design and application." *Information, Communications & Signal Processing, 2007 6th International Conference on*. IEEE, 2007.
- [5] Fear, Elise C., Paul M. Meaney, and Maria A. Stuchly. "Microwaves for breast cancer detection?." *IEEE potentials* 22.1 (2003): 12-18.
- [6] Hassan, Nouralhuda A., Moustafa M. Mohamed, and Mazher B. Tayel. "BASIC EVALUATION OF ANTENNAS USED IN MICROWAVE IMAGING FOR BREAST CANCER DETECTION." *Computer Science & Information Technology*: 55.
- [7] Wang, Xiong. "Thermoacoustic applications in breast cancer detection and communications." (2014).
- [8] Wang, Zhao, et al. "Medical applications of microwave imaging." *The Scientific World Journal* 2014 (2014).
- [9] Fujimoto, Kyōhei, and James R. James. *Mobile antenna systems handbook*. Artech House, 2001.
- [10] Mai, Ching-Chia, et al. "Antenna for GPS." U.S. Patent No. 7,652,633. 26 Jan. 2010.
- [11] Cui, Jun-Hong, et al. "The challenges of building mobile underwater wireless networks for aquatic applications." *Ieee Network* 20.3 (2006): 12-18.
- [12] Logan, J. C., and J. W. Rockway. *Dipole and Monopole Antenna Gain and Effective Area for Communication Formulas*. No. NRAD-TR-1756. NAVAL COMMAND CONTROL AND OCEAN SURVEILLANCE CENTER RDT AND E DIV SAN DIEGO CA, 1997.
- [13] Westcott, B. S. *Shaped reflector antenna design*. Vol. 3. Research Studies Press, New York, 1983.
- [14] Moernaut, Gerald JK, and D. Orban. "The basics of antenna arrays." *Orban Microwave Products* (2014).
- [15] Mailloux, Robert J. *Phased array antenna handbook*. Vol. 2. Boston: Artech House, 2005.

- [16] Stutzman, Warren L., and Gary A. Thiele. *Antenna theory and design*. John Wiley & Sons, 2012.
- [17] Kumar Abhishek, Kishor C. Kamal. "A Review on Operations & Applications of Lens Antenna." *International Journal of Electronics and Communication Engineering (SSRG-IJECE)*, Volume 3, Issue 8, August 2016
- [18] Kaur, Jaswinder Guide. *Design, fabrication and performance analysis of microstrip patch antennas for wireless applications*. Diss. 2013.
- [19] Orban, D., and G. J. K. Moernaut. "The basics of patch antennas, updated." *RF Globalnet (www.rfglobalnet.com) newsletter* (2009).
- [20] Ramachandran, Prasanna, et al. "Antenna Design, Simulation and Fabrication." *Dept of Electronics and Computer Science Engineering, Visvesvaraya National Institute of Technology* (2007).
- [21] Balanis, Constantine A. *Antenna theory: analysis and design*. John Wiley & Sons, 2016.
- [22] Pozar, David M. *Microwave engineering*. John Wiley & Sons, 2009.
- [23] Shanmuganatham, T., K. Balamaniandan, and S. Raghavan. "CPW-fed slot antenna for wideband applications." *International Journal of Antennas and Propagation* 2008 (2008).
- [24] Jou, Christina F., Jin-Wei Wu, and Chien-Jen Wang. "Novel broadband monopole antennas with dual-band circular polarization." *IEEE Transactions on Antennas and Propagation* 57.4 (2009): 1027-1034.
- [25] Jain, Kiran, and Keshav Gupta. "Different substrates use in Microstrip patch antenna-A survey." *Int J Sci Res* 3.5 (2014).
- [26] Bozdağ, Gökseven. *Novel microstrip antennas for multiband wideband applications*. MS thesis. İzmir Institute of Technology, 2014.
- [27] Simons, Rainee N. *Coplanar waveguide circuits, components, and systems*. Vol. 165. John Wiley & Sons, 2004.
- [28] Pues, Hugo F., and Antoine R. Van De Capelle. "An impedance-matching technique for increasing the bandwidth of microstrip antennas." *IEEE transactions on antennas and propagation* 37.11 (1989): 1345-1354.
- [29] Çelik, Ali Recai, M. Bahattin Kurt, and Selçuk Helhel. "Design an Ultra-Wide Band Antenna for Microwave Imaging Systems."
- [30] ANSYS, HFSS. "Ansoft Corp., Pittsburgh, PA." (2015).
- [31] P.A. Ambresh¹, P. M. Hadalgi, "Short Stub Microstrip Patch Antenna on Radiating Edges", *International Journal of Advanced Research in Electrical, Electronics and Instrumentation Engineering*, Vol. 2, Issue 6, June 2013.
- [32] Rafiqul, Islam Md, et al. "Design of microstrip patch antenna using slotted partial ground and addition of stairs and stubs for UWB application." *Cyber Journals: Multidisciplinary Journals in Science and Technology, Journal of Selected Areas in Telecommunications (JSAT)* (2012): 1-8.
- [33] Abbosh, Amin M. "Directive antenna for ultrawide band medical imaging systems." *International Journal of Antennas and Propagation* 2008 (2008).
- [34] Choi, Seok H., et al. "A new ultra-wideband antenna for UWB applications." *Microwave and optical technology letters* 40.5 (2004): 399-401.

- [35] Lim, Ka-Sing, Manimaran Nagalingam, and Chue-Poh Tan. "Design and construction of microstrip UWB antenna with time domain analysis." *Progress In Electromagnetics Research M* 3 (2008): 153-164.
- [36] Capobianco, A. D., et al. *Directive Ultra-Wideband Planar Antennas*. INTECH Open Access Publisher, 2010.
- [37] Liang, J., et al. "Printed circular disc monopole antenna for ultra-wideband applications." *Electronics letters* 40.20 (2004): 1246-1247.
- [38] Agrawal, Narayan P., Girish Kumar, and K. P. Ray. "Wide-band planar monopole antennas." *IEEE transactions on antennas and propagation* 46.2 (1998): 294-295.
- [39] Karamzadeh, Saeid. "A Novel Compact Polarization Diversity Ultra-Wideband MIMO Antenna." *Applied Computational Electromagnetics Society Journal* 32.1 (2017).
- [40] Zhang, Haoyu. "Microwave imaging for ultra-wideband antenna based cancer detection." (2015).
- [41] Haraz, Osama, and Abdel-Razik Sebak. *UWB antennas for wireless applications*. INTECH Open Access Publisher, 2013.

RESUME

Nasir Iqbal

Beşyol Mahallesi, İnönü Cd. No:38,
34295 Küçükçekmece/İstanbul, Turkey
Mobile: +923045866696,
+905051448796
Email: nasiriqbal1992@gmail.com



EDUCATION:

- Bachelors of Science (BS): NUCES-FAST
Major: Electrical Engineering
Grade: 2.52 cgpa
- Intermediate of Science (F.Sc) Peshawar Public School and College (2011)
Group: Pre-Engineering
Percentage: 76.0%
- Matriculation: Warsak Model School and College (2009)
Group: Science
Percentage: 76.9%

PERSONAL INFORMATION:

- D.O.B: 11 June, 1992
- Domicile: Malakand, Pakistan

COMPUTER SKILLS:

- Matlab
- Simulink
- High Frequency Structural Simulator (HFSS)
- Programming (C++,C)
- Simulation
- MS Office (MS Word, MS PowerPoint, MS Excel)

COMMUNICATION SKILLS:

- English Speak, Read, Write
- Pashto Speak, Read
- Urdu Speak, Read, Write

RESEARCH SKILLS:

I have done Final Year Project in Bachelors that was basis on Image Processing (3D Reconstruction). It was purely based on Simulation that is Computer Vision. It includes a lot of reseach options that modern world is looking for.

Currently, I have been working on antenna designing. My research is based on Microwave Imaging for cancer detection purpose.

TEACHING SKILLS:

I have delivered many presentations during my Bachelors, which provide me a great experience in terms of delivering lectures. Lab supervision is another task that is improved with my previous education.

INTERPERSONAL SKILLS:

- Active listening
- Punctual
- Persuasion
- Delegation

ACTIVITES AND INTERESTS:

- Badminton
- Sci-fi Movies
- Book Reading
- Studying Robotics
- Travelling
- Internet Surfing

SELECTED ACHIEVEMENTS:

- Participation in curricular and academic activities
- Organizing different occasions
- Extra-ordinary student record in all academic career